

| ATLANTIC VERSION TERMINATOR INTERFACE ADAPTER | PART NUMBER | REVISION | DESCRIPTION | FEED TYPE | CONVERT TO | PART NUMBERS REQUIRED | | | | | |
|---|-------------|--------------------------|--------------------------|-------------------|-------------------|-----------------------|-----------|-------------|-----------|-----------|------------------------|
| | 2151279-1 | B | FINE CRIMP HEIGHT ADJUST | MECHANICAL | PNEUMATIC FEED | 2119950-1 | 1338685-1 | 5-18022-5 | 2119641-1 | 2119799-1 | 2063440-1 |
| | 2151279-2 | B | FINE CRIMP HEIGHT ADJUST | PNEUMATIC | SERVO LATCH PLATE | 2119951-1 | - | 8-2151279-5 | 1901094-3 | - | 2168400-6 (QUANTITY 2) |
| | | | | | SMART APPLICATOR | 2161326-1 | - | 8-2151279-4 | - | - | |
| | | | | | MECHANICAL FEED | 2119949-1 | 1338685-1 | 5-18022-5 | 2119653-1 | - | - |
| | 2151279-5 | B | FINE CRIMP HEIGHT ADJUST | SERVO LATCH PLATE | SERVO LATCH PLATE | 2119951-1 | - | 8-2151279-5 | 1901094-3 | - | 2168400-6 (QUANTITY 2) |
| | | | | | SMART APPLICATOR | 2161326-1 | - | 8-2151279-4 | - | - | |
| | 2151279-6 | B | NON-CRIMP HEIGHT ADJUST | SERVO LATCH PLATE | MECHANICAL FEED | 2119949-1 | 1338685-1 | 5-18022-5 | 2119653-1 | - | - |
| 2151279-7 | B | FINE CRIMP HEIGHT ADJUST | NONE | PNEUMATIC FEED | 2119950-1 | 1338685-1 | 5-18022-5 | 2119641-1 | 2119799-1 | 2063440-1 | |
| 7-2151279-7 | A | CRIMP TOOLING KIT | - | - | - | - | - | - | - | - | |

| APPLICATOR DATA | | |
|-----------------------------------|----------------|------|
| CRIMP WIRE | SIZE | TYPE |
| WIRE | 2.03 mm [.080] | F |
| INSUL | 2.54 mm [.100] | O |
| APPLICATOR INSTRUCTIONS 408-10389 | | |

| TERMINAL DATA: TE TERMINAL | | TE CRIMP SPECIFICATION | |
|--------------------------------------|------------------------------|------------------------|--------------|
| TERMINAL NAME: MICRO TIMER 2 CONTACT | | | |
| WIRE STRIP LENGTH | INSULATION DIAMETER RANGE | | |
| 4.00-4.60 mm [.157-.181 IN] | Ø1.40-2.10 mm [.055-.083 IN] | | |
| TERMINAL APPLICATION SPECIFICATION | | | |
| (A) 1114-18081 | | | |
| (B) 1114-18082 | | | |
| TERMINALS APPLIED | | | |
| TE TERMINAL | TE TERMINAL | TE TERMINAL | TE TERMINAL |
| (A) 962943-1 | (A) 962943-5 | (B) 962948-2 | (B) 963900-4 |
| (A) 962943-2 | (A) 962943-6 | (B) 963900-1 | |
| (A) 962943-3 | (A) 968052-1 | (B) 963900-2 | |
| (A) 962943-4 | (B) 962948-1 | (B) 963900-3 | |

| WIRE SIZE | CRIMP HEIGHT mm [INCH] | CRIMP HEIGHT REFERENCE SETTING |
|-----------|----------------------------|--------------------------------|
| 1.00mm2 | 1.20+/-0.05 [.047+/-0.002] | 5.0 |
| 0.75mm2 | 1.18+/-0.05 [.046+/-0.002] | 5.2 |
| 0.50mm2 | 1.15+/-0.05 [.045+/-0.002] | 5.3 |

- 1 RECOMMENDED SPARE PARTS
- 2 GREASE BEARING SURFACES LIGHTLY
- 3. LUBRICATE DAILY PER THE APPLICATOR INSTRUCTION SHEET SUPPLIED WITH THE APPLICATOR.
- 4 APPLICATOR SPECIFIC DATA TO BE ENTERED INTO BLANK MEMORY CHIP AT ASSEMBLY. SEE BELOW FOR PART NUMBER:
 MECHANICAL FEED WITH "SMART APPLICATOR" CONVERSION: 8-2151279-4
 PNEUMATIC FEED WITH "SMART APPLICATOR" CONVERSION: 8-2151279-4
 SERVO FEED WITH "FINE CRIMP HEIGHT ADJUST": 8-2151279-5
 SERVO FEED WITH "NON-CRIMP HEIGHT ADJUST": 8-2151279-6
- 5. ADJUSTMENT OF THE STRIPPER MAY BE REQUIRED WHEN MOVING THE APPLICATOR BETWEEN BENCH AND LEADMAKER APPLICATIONS.
- 6 APPLY PART NUMBER 1-23419-5 LOCTITE TO THREADS OF ITEM 50.62 & 242 FOR -6 ONLY APPLY PART NUMBER 1-23419-5 LOCTITE TO THREADS OF ITEM 37.50 & 242.
- 7 GREASE THREADS, GROOVE AND O-RING ON ITEMS 35 & 252.
- 8 MAGNET, ITEM 166 MUST BE ORIENTED CORRECTLY IN ORDER TO PROPERLY ACTUATE THE COUNTER.
- 9 CRIMP HEIGHT REFERENCE SETTING WAS THE SETTING USED WHEN THE APPLICATOR WAS QUALIFIED AT THE FACTORY. ADJUSTMENT MAY BE NECESSARY WHEN RUNNING APPLICATOR IN THE FIELD.
- 10 SPARE FEED CAM STORAGE LOCATION REFER TO INSTRUCTION SHEET FOR ADDITIONAL INFORMATION.
- 11 TO CONVERT THE APPLICATOR TO A NON-CARRIER CUTTING STYLE, REMOVE ITEM 13 AND ATTACH TO THE LOCATION ON THE BACK SIDE OF THE HOUSING. REFER TO INSTRUCTION SHEET FOR ADDITIONAL INFORMATION.
- 12 WHEN ASSEMBLING -6 NON-CRIMP HEIGHT ADJUST APPLICATOR USE SHIM PACK 2119957-2 TO ALIGN APPLICATOR'S MAXIMUM WIRE CRIMP HEIGHT AT NORMAL TERMINATOR SHUT HEIGHT

***WARNING**
 ON INSTALLATION, SET WIRE DISC, ITEM 40 TO LARGEST WIRE SIZE SETTING. USE OF SETTINGS BELOW MINIMUM REQUIRED CRIMP HEIGHT SETTING WILL CAUSE DAMAGE TO CRIMP TOOLING.

| | | | | | | | | |
|-----|----|----|----|----|----|-----------|---------------------------------|---------|
| - | - | 1 | - | - | - | 2119957-2 | APPLICATOR SHIM PACK | 260 |
| - | 1 | - | 1 | 1 | 1 | 8-21084-0 | O-RING, .676 ID, .070 DIA. MAT. | 252 |
| - | - | - | - | 1 | - | 2119640-1 | PUSH ROD, AIR FEED | 250 |
| - | - | - | - | 1 | - | 2079988-1 | BUSHING, LCH5-12, MISUMI | 249 |
| - | - | - | - | 1 | - | 2119641-1 | FEED CAM, AIR FEED | 248 |
| -77 | -7 | -6 | -5 | -2 | -1 | PART NO | DESCRIPTION | ITEM NO |

ATLANTIC VERSION
 Shown on sheets 1 of 4 & 2 of 4
 (Pacific version shown on sheets 3 of 4 & 4 of 4)

| SET UP GAUGE | LOC | DIST | REVISIONS | | | | | |
|--------------|-----|------|-----------|-----|-----------------------|-----------|-----|------|
| 2119599-1 | A | 66 | P | LTN | DESCRIPTION | DATE | OWN | APVD |
| | | | A | | RELEASED | 06APR2012 | KH | SX |
| | | | B | | REVISED ECR-13-005732 | 03APR2013 | CC | TE |

| | | | | | | | | |
|-----|-----|-----|-----|-----|-----|-------------|-------------------------------------|---------|
| - | 1 | - | 1 | 1 | 1 | 2119798-1 | DETENT PIN | 247 |
| - | 1 | - | 1 | 1 | 1 | 1-22279-3 | SPRING, COMPRESSION | 246 |
| - | - | 1 | - | - | - | 2119758-1 | RAM, AMP STYLE, SIDE FEED, NON-ADJ. | 245 |
| - | 1 | 1 | 1 | 1 | 1 | 2119082-9 | CAM, SNAIL, INSULATION ADJUSTMENT | 244 |
| - | 1 | 1 | 1 | 1 | 1 | 2079764-1 | WASHER, WAVE SPRING, CREST-TO-CREST | 243 |
| - | 1 | 1 | 1 | 1 | 1 | 2119083-1 | RETAINER, INSULATION DIAL | 242 |
| - | 1 | 1 | 1 | 1 | 1 | 7-18023-7 | SCR, SKT HD CAP M3 X 4.0 | 241 |
| - | - | 2 | 2 | - | - | 2168400-6 | SHCS, LOW HEAD, RoHS, M5 X 16 | 240 |
| - | - | - | - | - | 1 | 2119580-1 | MECHANICAL FEED ASSEMBLY | 239 |
| - | - | - | - | - | 1 | 2063440-1 | AIR FEED MODULE | 238 |
| - | - | 1 | 1 | - | - | 2119740-2 | TAG, IDENTIFICATION | 213 |
| - | - | 1 | 1 | - | - | 1901094-3 | SPACER, FEEDER | 198 |
| - | 1 | 1 | 1 | 1 | 1 | 993111-1 | PIN, SLOTTED SPRING 3.0 X 20.0 | 177 |
| - | 1 | 1 | 1 | 1 | 1 | 8-22280-7 | SPRING, COMPRESSION | 176 |
| - | 1 | 1 | 1 | 1 | 1 | 1752353-2 | GUIDE PIN, HOLDDOWN | 175 |
| - | 1 | 1 | 1 | 1 | 1 | 1901680-2 | GUIDE PIN, HOLDDOWN | 174 |
| - | - | - | - | 2 | - | 21045-3 | RING, RETAIN, EXTERN, 3/16 CRESCENT | 172 |
| - | 1 | 1 | 1 | 1 | 1 | 994969-1 | MAGNET, RARE EARTH HIGH ENERGY | 166 |
| - | REF | REF | REF | REF | REF | 994970-2 | COUNTER, MAGNETIC | 164 |
| - | - | - | - | 1 | - | 240638-1 | SPRING, FEED FINGER | 163 |
| - | - | - | - | 1 | - | 3-23627-7 | PIN, RETAIN, GRVD, 3/16 X .854 | 137 |
| - | - | - | - | 1 | - | 2119799-1 | HOLDER, FEED FINGER, AF | 136 |
| - | - | REF | REF | - | - | SEE NOTE 4 | MEMORY CHIP, PROGRAMMED | 135 |
| - | - | 1 | 1 | - | - | 1633743-1 | SERVO FEED LATCH ASM | 133 |
| - | 1 | 1 | 1 | 1 | 1 | 1-18028-2 | WASHER, FLAT, REG M4 | 119 |
| - | - | REF | REF | - | - | 2119944-1 | FEED FINGER ASSEMBLY, SF | 117 |
| - | 1 | 1 | 1 | 1 | 1 | 455888-5 | SPACER, CRIMPER | 82 |
| - | 1 | 1 | 1 | 1 | 1 | 2119956-1 | DOCUMENTATION PACKAGE | 71 |
| - | 1 | - | - | 1 | 1 | 2119740-1 | TAG, IDENTIFICATION | 67 |
| - | 2 | 2 | 2 | 2 | 2 | 2168078-1 | SCREW, DRIVE, RH, RoHS | 66 |
| - | 1 | - | 1 | 1 | 1 | 2119793-1 | LIMITER, ADJUSTMENT BOLT | 63 |
| - | 3 | - | 3 | 3 | 3 | 992763-5 | SCR, SET, SOC, CONE POINT, M3 x 4.0 | 62 |
| - | 1 | 1 | 1 | 1 | 1 | 2079383-4 | SCR, BHSC, RoHS (M4 X 8) | 60 |
| - | - | - | - | 1 | 1 | 5-18022-5 | SCR, HEX HD CAP, M4 X 6.0 | 59 |
| - | - | - | - | 1 | 1 | 1338685-1 | PAWL, FEED | 56 |
| - | 4 | 4 | 4 | 4 | 4 | 2168400-1 | SHCS, LOW HEAD, RoHS, M4 X 12 | 54 |
| - | 1 | 1 | 1 | 1 | 1 | 1-5018030-0 | NUT, HEX, REG, RoHS, M3.5 | 52 |
| - | 1 | 1 | 1 | 1 | 1 | 1901681-1 | HOLDDOWN, TERMINAL | 51 |
| - | 1 | 1 | 1 | 1 | 1 | 1-1752354-7 | STANDOFF, HOLD-DOWN | 50 |
| - | - | - | - | 1 | 2 | 18023-9 | SCR, SKT HD CAP M4 X 6.0 | 49 |
| - | - | - | - | - | 1 | 2119652-1 | FEED CAM, PRE FEED | 48 |
| - | - | - | - | - | 1 | 2119653-1 | FEED CAM, POST FEED | 47 |
| - | 1 | 1 | 1 | 1 | 1 | 2119656-9 | APPLICATOR BASIC ASSEMBLY, SF | 46 |
| - | 1 | - | 1 | 1 | 1 | 2119370-1 | RAM, AMP STYLE, SIDE FEED | 44 |
| - | 1 | 1 | 1 | 1 | 1 | 2079383-7 | SCR, BHSC, RoHS (M8 X 25) | 41 |
| - | 1 | - | 1 | 1 | 1 | 2119645-1 | DISC, NUMBERED FA WIRE ADJUSTMENT | 40 |
| - | 1 | - | 1 | 1 | 1 | 2119957-1 | APPLICATOR SHIM PACK | 39 |
| - | 1 | 1 | 1 | 1 | 1 | 2119644-1 | RAM WASHER, PRECISION | 38 |
| - | 1 | 1 | 1 | 1 | 1 | 2119085-1 | FA HEAD, ATLANTIC STYLE | 37 |
| - | 1 | - | 1 | 1 | 1 | 2119092-1 | BOLT, ADJUSTMENT | 35 |
| - | 1 | 1 | 1 | 1 | 1 | 1-1752356-8 | SUPPORT, TERMINAL | 34 |
| - | 2 | 2 | 2 | 2 | 2 | 2079383-5 | SCR, BHSC, RoHS (M4 X 20) | 33 |
| - | 1 | 1 | 1 | 1 | 1 | 2161328-1 | HEX HEAD, FLANGED, M5 x 8mm LONG | 32 |
| - | 1 | 1 | 1 | 1 | 1 | 1-1320908-0 | SPACER, STRIP GUIDE | 30 |
| - | 1 | 1 | 1 | 1 | 1 | 2119959-2 | ASSEMBLY, STRIP GUIDE | 29 |
| - | 1 | 1 | 1 | 1 | 1 | 1-455888-0 | SPACER, CRIMPER | 28 |
| - | 1 | 1 | 1 | 1 | 1 | 1320928-2 | STRIP GUIDE | 24 |
| - | 1 | 1 | 1 | 1 | 1 | 2168083-2 | SCR, SKT HD CAP, RoHS, M4 X 8.0 | 21 |
| - | 1 | 1 | 1 | 1 | 1 | 1-18028-2 | WASHER, FLAT, REG M4 | 20 |
| - | 1 | 1 | 1 | 1 | 1 | 2119533-1 | STRIPPER, SIDE FEED | 19 |
| - | 1 | 1 | 1 | 1 | 1 | 2119806-1 | INSERT, SHEAR | 13 |
| - | 1 | 1 | 1 | 1 | 1 | 3-22280-3 | SPRING, COMPRESSION | 12 |
| - | 1 | 1 | 1 | 1 | 1 | 1-356885-4 | STOP, SHEAR | 11 |
| - | 1 | 1 | 1 | 1 | 1 | 2119805-1 | SHEAR HOLDER, FRONT | 10 |
| - | 1 | 1 | 1 | 1 | 1 | 454276-5 | FLOATING SHEAR, FRONT | 9 |
| - | 1 | 1 | 1 | 1 | 1 | 1-1333204-5 | ANVIL, COMBINATION | 8 |
| - | - | - | - | - | - | - | - | 7 |
| - | - | - | - | - | - | - | - | 6 |
| - | 1 | 1 | 1 | 1 | 1 | 2119757-4 | DEPRESSOR, SHEAR | 5 |
| - | 1 | 1 | 1 | 1 | 1 | 238011-4 | BLOCK, CRIMPER SPACER | 4 |
| - | 1 | 1 | 1 | 1 | 1 | 4-2119784-0 | CRIMPER, INSULATION O PREMIUM | 3 |
| - | 1 | 1 | 1 | 1 | 1 | 1-455888-3 | SPACER, CRIMPER | 2 |
| - | 1 | 1 | 1 | 1 | 1 | 1-456405-6 | CRIMPER, WIRE PREMIUM | 1 |
| -77 | -7 | -6 | -5 | -2 | -1 | PART NO | DESCRIPTION | ITEM NO |

| DIMENSIONS: | | TOLERANCES UNLESS OTHERWISE SPECIFIED: | | DRAWING NO | | REVISIONS | |
|--|-----------|--|------------|------------|--------------|--------------|--------|
| mm | 0 PLC ±.1 | 1 PLC ±.01 | 2 PLC ±.02 | 3 PLC ±.05 | 4 PLC ±.0005 | ANGLES ±.1 | FINISH |
| MATERIAL | | FINISH | | WEIGHT | | SCALE | |
| | | | | A1 00779 | | C=2151279 | |
| Customer Accessible Production Drawing | | | | SCALE | | SHEET 1 OF 4 | |

| LOC | | DIST | | REVISIONS | | | |
|-----|----|------|-----|-------------|------|-----|------|
| A | 66 | P | LTM | DESCRIPTION | DATE | OWN | APVD |
| | | - | - | SEE SHEET 1 | - | - | - |

FEED TYPE MECHANICAL

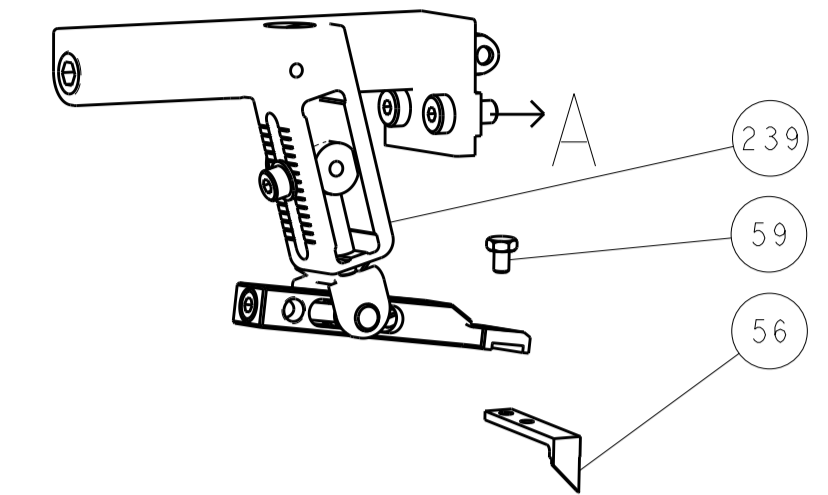

PNEUMATIC

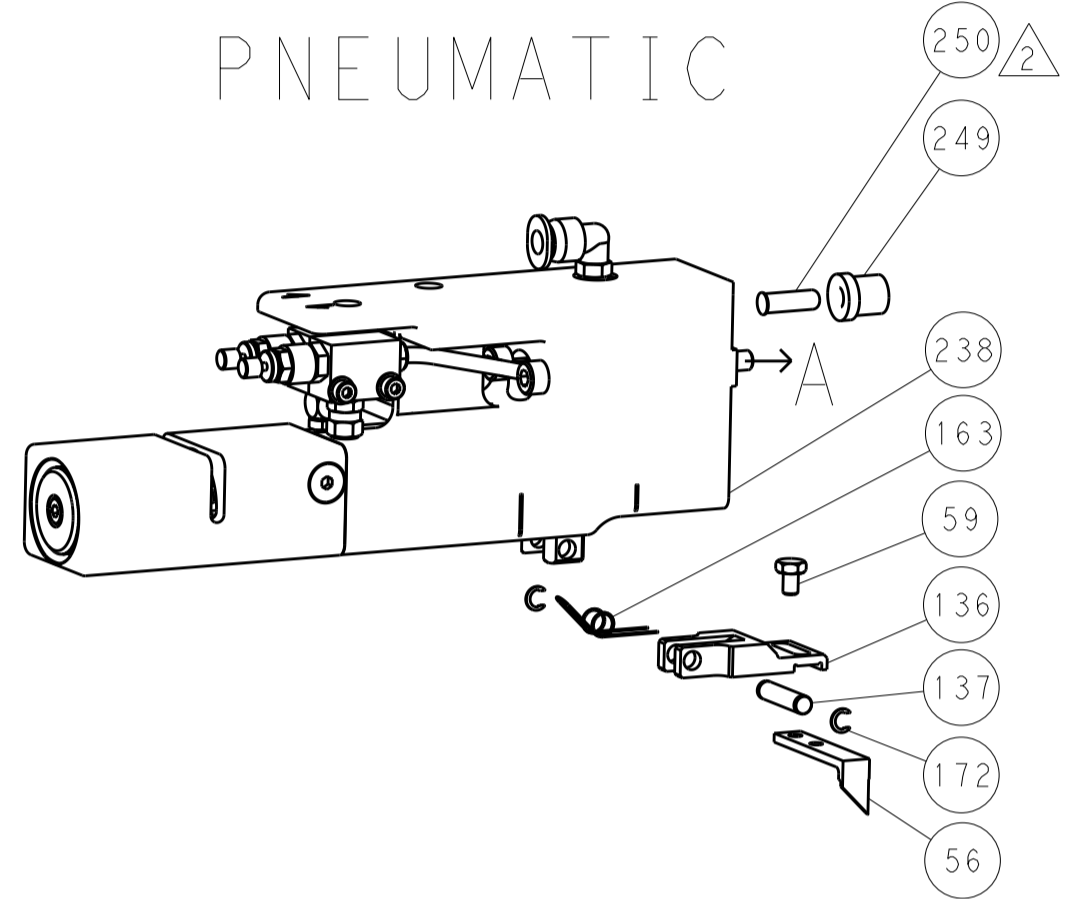

SERVO LATCH PLATE

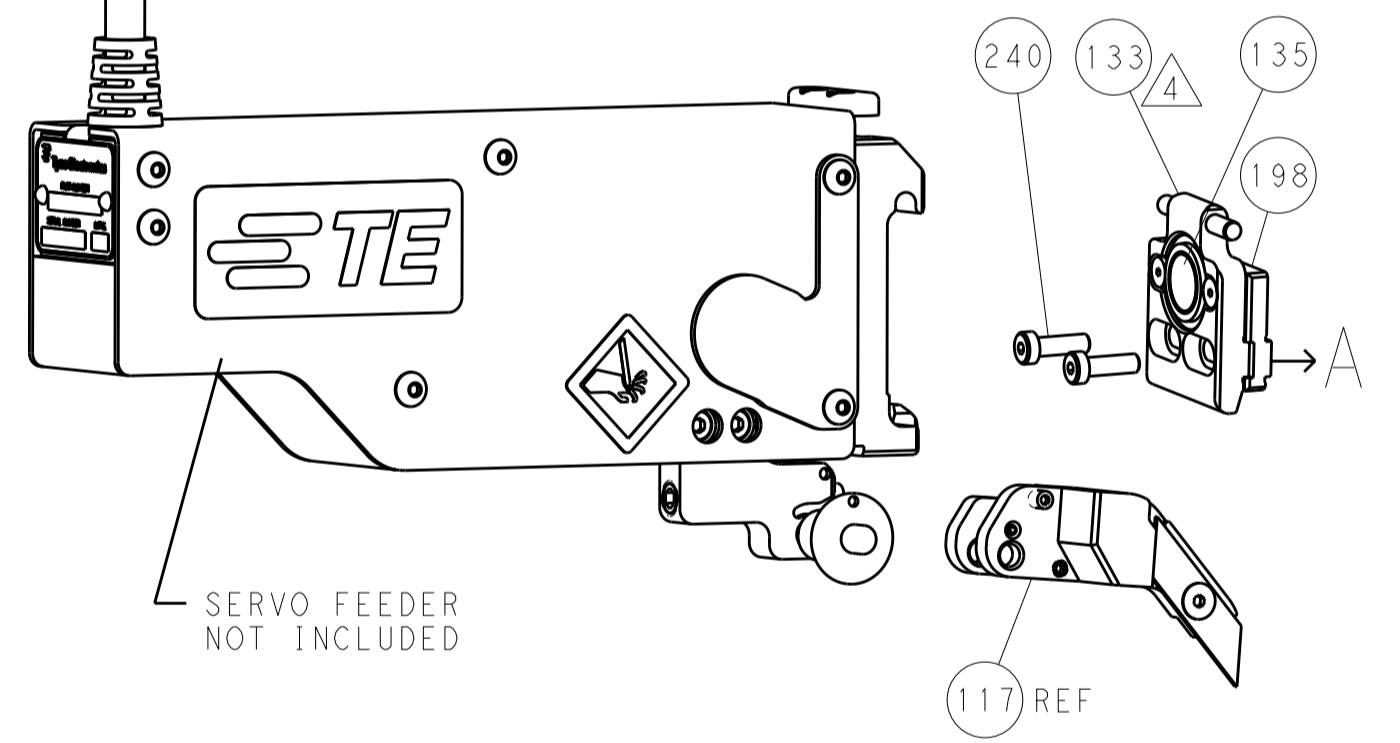

CAM POSITIONS

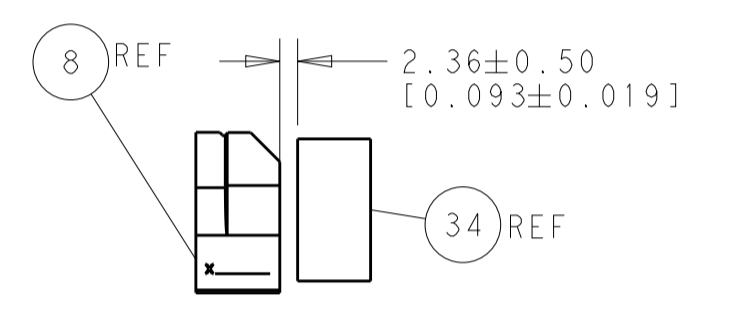
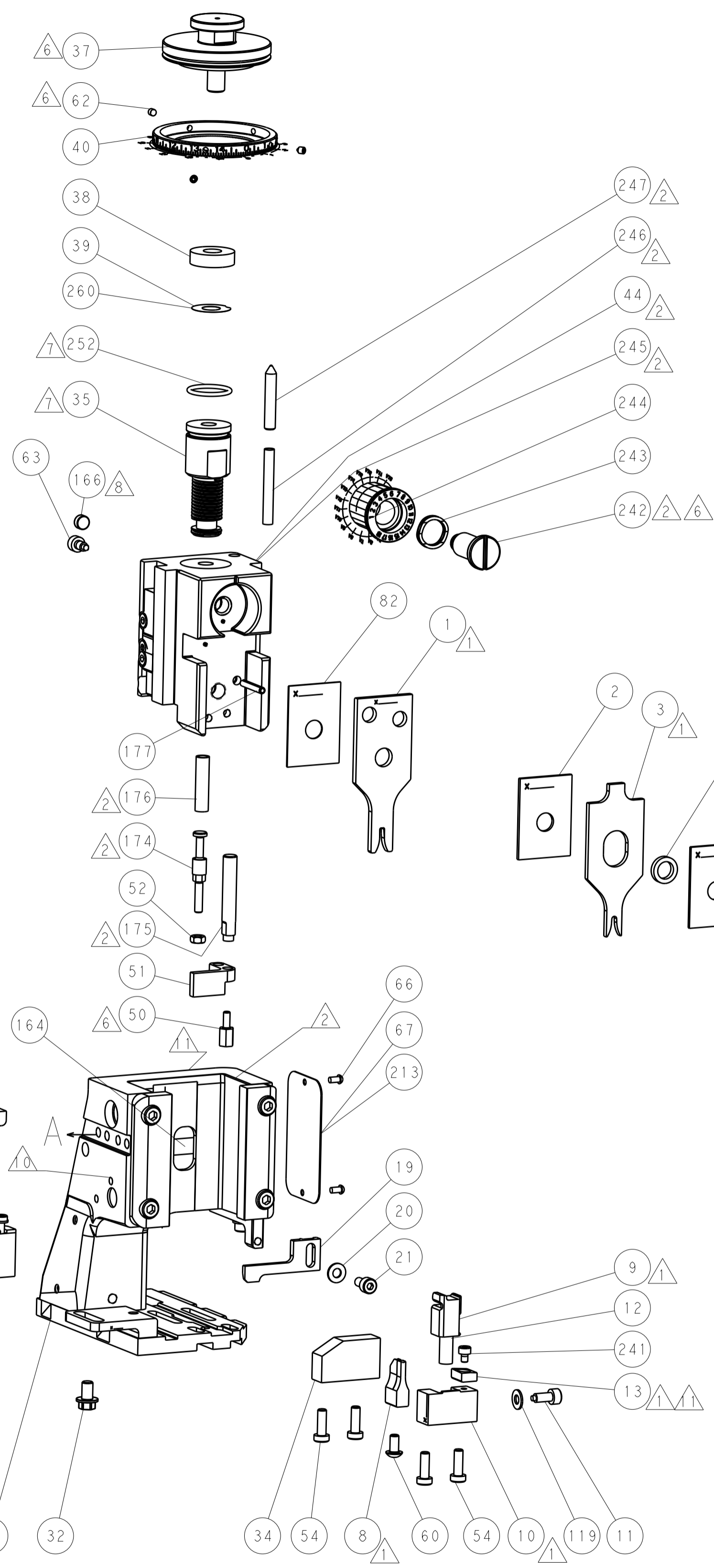
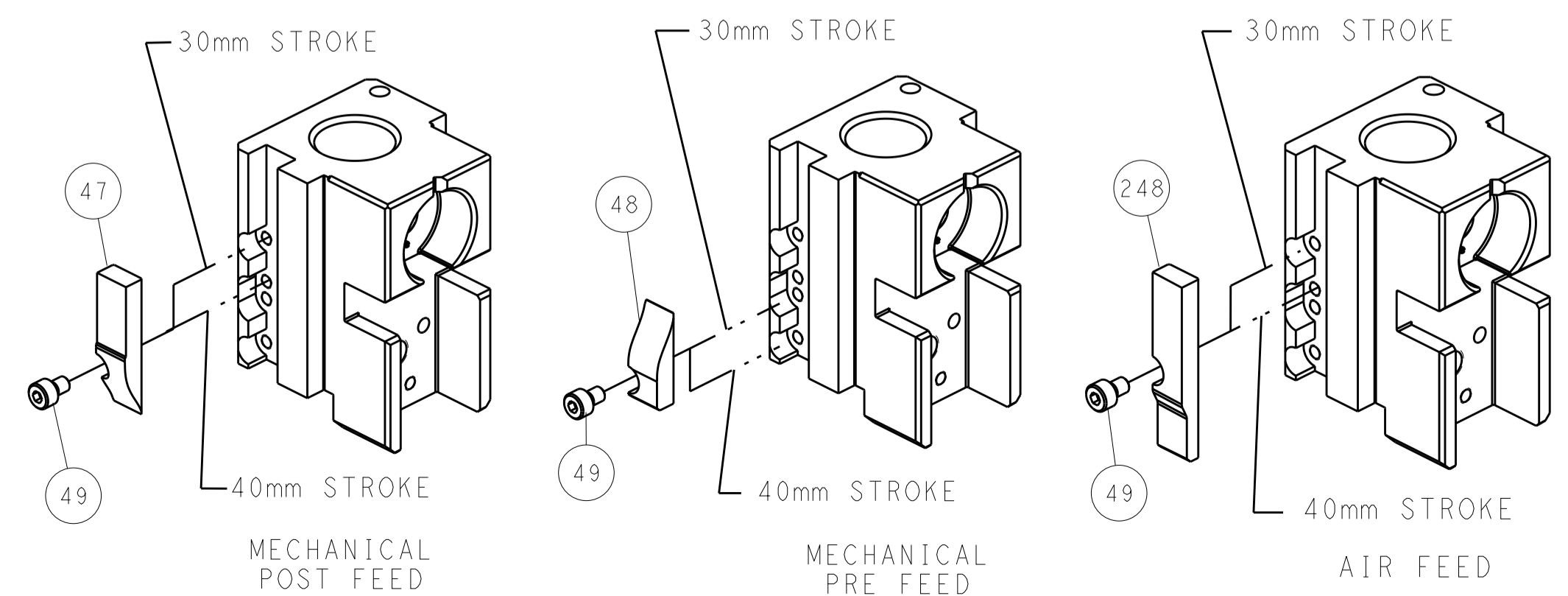

TERMINAL SUPPORT LOCATION

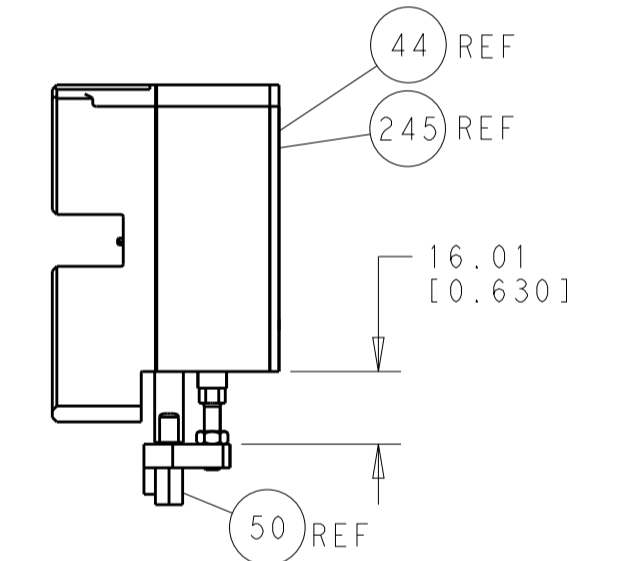

HOLDDOWN SET-UP

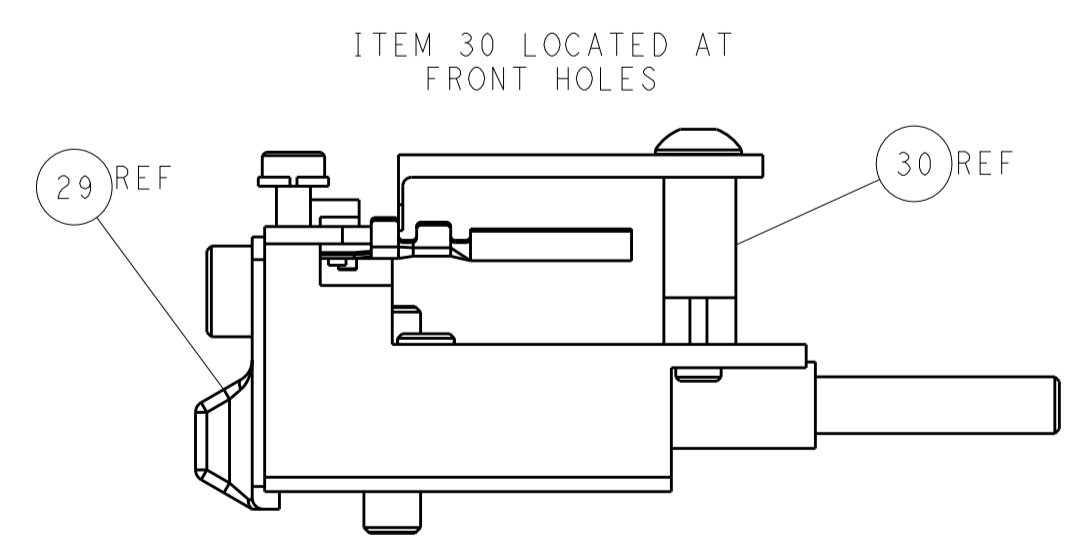

FEED TRACK POSITION GUIDE BY INSULATION BARREL

ATLANTIC VERSION
 Shown on sheets 1 of 4 & 2 of 4
 (Pacific version shown on sheets 3 of 4 & 4 of 4)

| | | | | | | | |
|-------------|------------|--|-------------|-------------------------|---------------|----------------------------------|---|
| DIMENSIONS: | | TOLERANCES UNLESS OTHERWISE SPECIFIED: | | DWN: H. HUANG 09DEC2011 | | TE Connectivity | |
| mm | 0 PLC ±0.1 | 1 PLC ±0.1 | 2 PLC ±0.02 | 3 PLC ±0.005 | 4 PLC ±0.0005 | ANGLES ±0.0005 | TE Connectivity Harrisburg, PA 17105-3608 |
| MATERIAL: | | | | CHK: S. XI 09DEC2011 | | NAME: OCEAN SIDE FEED APPLICATOR | |
| FINISH: | | | | APVD: J. CRUZ 09DEC2011 | | PRODUCT SPEC: | |
| MATERIAL: | | | | APVD: J. CRUZ 09DEC2011 | | APPLICATION SPEC: | |
| MATERIAL: | | | | APVD: J. CRUZ 09DEC2011 | | WEIGHT: | |
| MATERIAL: | | | | APVD: J. CRUZ 09DEC2011 | | SCALE: 1:1 SHEET 2 OF 4 REV B | |

| PACIFIC VERSION TERMINATOR INTERFACE ADAPTER | PART NUMBER | REVISION | DESCRIPTION | FEED TYPE | APPLICATOR STYLE CONVERSION CHART | | | | | | |
|--|-------------|----------|--------------------------|-------------------|-----------------------------------|-----------------------|-----------|-------------|-----------|-----------|------------------------|
| | | | | | CONVERT TO | PART NUMBERS REQUIRED | | | | | |
| | 2-2151279-1 | B | FINE CRIMP HEIGHT ADJUST | MECHANICAL | PNEUMATIC FEED | 2119950-1 | 1338685-1 | 5-18022-5 | 2119641-2 | 2119799-1 | 2063440-1 |
| | | | | | SERVO LATCH PLATE | 2119951-1 | - | 8-2151279-5 | 1901094-3 | - | 2168400-6 (QUANTITY 2) |
| | | | | | SMART APPLICATOR | 2161326-1 | - | 8-2151279-4 | - | - | - |
| | 2-2151279-2 | B | FINE CRIMP HEIGHT ADJUST | PNEUMATIC | MECHANICAL FEED | 2119949-1 | 1338685-1 | 5-18022-5 | 2119653-2 | - | - |
| | | | | | SERVO LATCH PLATE | 2119951-1 | - | 8-2151279-5 | 1901094-3 | - | 2168400-6 (QUANTITY 2) |
| | | | | | SMART APPLICATOR | 2161326-1 | - | 8-2151279-4 | - | - | - |
| | 2-2151279-5 | B | FINE CRIMP HEIGHT ADJUST | SERVO LATCH PLATE | MECHANICAL FEED | 2119949-1 | 1338685-1 | 5-18022-5 | 2119653-2 | - | - |
| | | | | | PNEUMATIC FEED | 2119950-1 | 1338685-1 | 5-18022-5 | 2119641-2 | 2119799-1 | 2063440-1 |
| | 2-2151279-7 | B | FINE CRIMP HEIGHT ADJUST | NONE | - | - | - | - | - | - | - |
| | 7-2151279-7 | A | CRIMP TOOLING KIT | - | - | - | - | - | - | - | - |

| APPLICATOR DATA | | |
|--------------------------------------|----------------|------|
| CRIMP | SIZE | TYPE |
| WIRE | 2.03 mm [.080] | F |
| INSUL | 2.54 mm [.100] | O |
| APPLICATOR INSTRUCTIONS 408-10389 | | |

| TERMINAL DATA: TE TERMINAL | | TE CRIMP SPECIFICATION | |
|--------------------------------------|--------------|------------------------------|--------------|
| TERMINAL NAME: MICRO TIMER 2 CONTACT | | | |
| WIRE STRIP LENGTH | | INSULATION DIAMETER RANGE | |
| 4.00-4.60 mm [1.57-.181 IN] | | Ø1.40-2.10 mm [.055-.083 IN] | |
| TERMINAL APPLICATION SPECIFICATION | (A)114-18081 | | |
| | (B)114-18082 | | |
| TERMINALS APPLIED | | | |
| TE TERMINAL | TE TERMINAL | TE TERMINAL | TE TERMINAL |
| (A) 962943-1 | (A) 962943-5 | (B) 962948-2 | (B) 963900-4 |
| (A) 962943-2 | (A) 962943-6 | (B) 963900-1 | |
| (A) 962943-3 | (A) 968052-1 | (B) 963900-2 | |
| (A) 962943-4 | (B) 962948-1 | (B) 963900-3 | |

| WIRE SIZE | CRIMP HEIGHT mm [INCH] | CRIMP HEIGHT REFERENCE SETTING |
|-----------|-----------------------------|--------------------------------|
| 1.00mm2 | 1.20+/-0.05 [1.047+/-0.002] | 5.0 |
| 0.75mm2 | 1.18+/-0.05 [1.046+/-0.002] | 5.2 |
| 0.50mm2 | 1.15+/-0.05 [1.045+/-0.002] | 5.3 |

- RECOMMENDED SPARE PARTS
- GREASE BEARING SURFACES LIGHTLY
- 3. LUBRICATE DAILY PER THE APPLICATOR INSTRUCTION SHEET SUPPLIED WITH THE APPLICATOR.
- APPLICATOR SPECIFIC DATA TO BE ENTERED INTO BLANK MEMORY CHIP AT ASSEMBLY. SEE BELOW FOR PART NUMBER:
 MECHANICAL FEED WITH "SMART APPLICATOR" CONVERSION: 8-2151279-4
 PNEUMATIC FEED WITH "SMART APPLICATOR" CONVERSION: 8-2151279-4
 SERVO FEED WITH "FINE CRIMP HEIGHT ADJUST": 8-2151279-5
- 5. ADJUSTMENT OF THE STRIPPER MAY BE REQUIRED WHEN MOVING THE APPLICATOR BETWEEN BENCH AND LEADMAKER APPLICATIONS.
- APPLY PART NUMBER 1-23419-5 LOCTITE TO THREADS OF ITEM 50.62 & 242.
- GREASE THREADS, GROOVE AND O-RING ON ITEMS 139 & 152.
- MAGNET MUST BE ORIENTED CORRECTLY IN ORDER TO PROPERLY ACTUATE THE COUNTER.
- CRIMP HEIGHT REFERENCE SETTING WAS THE SETTING USED WHEN THE APPLICATOR WAS QUALIFIED AT THE FACTORY. ADJUSTMENT MAY BE NECESSARY WHEN RUNNING APPLICATOR IN THE FIELD.
- SPARE FEED CAM STORAGE LOCATION REFER TO INSTRUCTION SHEET FOR ADDITIONAL INFORMATION.
- TO CONVERT THE APPLICATOR TO A NON-CARRIER CUTTING STYLE, REMOVE ITEM 13 AND ATTACH TO THE LOCATION ON BACK SIDE OF THE HOUSING. REFER TO INSTRUCTION SHEET FOR ADDITIONAL INFORMATION.

***WARNING**
 ON INSTALLATION, SET WIRE DISC, ITEM 40 TO LARGEST WIRE SIZE SETTING. USE OF SETTINGS BELOW MINIMUM REQUIRED CRIMP HEIGHT SETTING WILL CAUSE DAMAGE TO CRIMP TOOLING.

| | | | | | | | |
|-----|-----|-----|-----|-----|-----------|-------------------------------------|---------|
| - | 1 | 1 | 1 | 1 | 2119782-1 | FINE ADJUST HEAD ASM, PACIFIC STYLE | 251 |
| - | - | - | 1 | - | 2119640-1 | PUSH ROD, AIR FEED | 250 |
| - | - | - | 1 | - | 2079988-1 | BUSHING, LCH5-12, MISUMI | 249 |
| -77 | -27 | -25 | -22 | -21 | PART NO | DESCRIPTION | ITEM NO |

PACIFIC VERSION
 Shown on sheets 3 of 4 & 4 of 4
 (Atlantic version shown on sheets 1 of 4 & 2 of 4)

| SET UP GAUGE | LOC | DIST | REVISIONS | | | | | |
|--------------|-----|------|-----------|-----|-------------|------|-----|------|
| 2119599-1 | A | 66 | P | LTN | DESCRIPTION | DATE | OWN | APVD |
| | | | - | - | SEE SHEET 1 | - | - | - |

| | | | | | | | |
|-----|-----|-----|-----|-----|-------------|-------------------------------------|---------|
| - | 1 | 1 | 1 | 1 | 1-22279-3 | SPRING, COMPRESSION | 246 |
| - | 1 | 1 | 1 | 1 | 2119082-9 | CAM, SNAIL, INSULATION ADJUSTMENT | 244 |
| - | 1 | 1 | 1 | 1 | 2079764-1 | WASHER, WAVE SPRING, CREST-TO-CREST | 243 |
| - | 1 | 1 | 1 | 1 | 2119083-1 | RETAINER, INSULATION DIAL | 242 |
| - | 1 | 1 | 1 | 1 | 7-18023-7 | SCR, SKT HD CAP M3 X 4.0 | 241 |
| - | - | 2 | - | - | 2168400-6 | SHCS, LOW HEAD, RoHS, M5 X 16 | 240 |
| - | - | - | - | 1 | 2119580-1 | MECHANICAL FEED ASSEMBLY | 239 |
| - | - | - | 1 | - | 2063440-1 | AIR FEED MODULE | 238 |
| - | - | 1 | - | - | 2119740-2 | TAG, IDENTIFICATION | 213 |
| - | - | 1 | - | - | 1901094-3 | SPACER, FEEDER | 198 |
| - | 1 | 1 | 1 | 1 | 993111-1 | PIN, SLOTTED SPRING 3.0 X 20.0 | 177 |
| - | 1 | 1 | 1 | 1 | 8-22280-7 | SPRING, COMPRESSION | 176 |
| - | 1 | 1 | 1 | 1 | 1752353-2 | GUIDE PIN, HOLDDOWN | 175 |
| - | 1 | 1 | 1 | 1 | 1901680-2 | GUIDE PIN, HOLDDOWN | 174 |
| - | - | - | 2 | - | 21045-3 | RING, RETAIN, EXTERN, 3/16 CRESCENT | 172 |
| - | 1 | 1 | 1 | 1 | 994969-1 | MAGNET, RARE EARTH HIGH ENERGY | 166 |
| - | REF | REF | REF | REF | 994970-2 | COUNTER, MAGNETIC | 164 |
| - | - | - | 1 | - | 240638-1 | SPRING, FEED FINGER | 163 |
| - | 1 | 1 | 1 | 1 | 8-21084-1 | O-RING, .801 ID, .070 DIA. MAT. | 152 |
| - | - | - | 1 | - | 2119641-2 | FEED CAM, AIR FEED | 151 |
| - | 1 | 1 | 1 | 1 | 2119798-2 | DETENT PIN | 145 |
| - | 1 | 1 | 1 | 1 | 2079383-8 | SCR, BHSC, RoHS (M4 X 16) | 144 |
| - | 4 | 4 | 4 | 4 | 2168400-5 | SHCS, LOW HEAD, RoHS, M4 X 20 | 143 |
| - | - | - | - | 1 | 2119653-2 | FEED CAM, POST FEED | 142 |
| - | 1 | 1 | 1 | 1 | 1-2119656-0 | APPLICATOR BASIC ASSEMBLY, SF | 141 |
| - | 1 | 1 | 1 | 1 | 2119650-1 | RAM, ASIAN STYLE, SIDE FEED | 140 |
| - | 1 | 1 | 1 | 1 | 2119092-2 | BOLT, ADJUSTMENT | 139 |
| - | - | - | 1 | - | 3-23627-7 | PIN, RETAIN, GRVD, 3/16 X .854 | 137 |
| - | - | - | 1 | - | 2119799-1 | HOLDER, FEED FINGER, AF | 136 |
| - | - | REF | - | - | SEE NOTE 4 | MEMORY CHIP, PROGRAMMED | 135 |
| - | - | 1 | - | - | 1633743-1 | SERVO FEED LATCH ASM | 133 |
| - | 1 | 1 | 1 | 1 | 1-18028-2 | WASHER, FLAT, REG M4 | 119 |
| - | - | REF | - | - | 2119944-1 | FEED FINGER ASSEMBLY, SF | 117 |
| - | 1 | 1 | 1 | 1 | 455888-5 | SPACER, CRIMPER | 82 |
| - | 1 | 1 | 1 | 1 | 2119956-1 | DOCUMENTATION PACKAGE | 71 |
| - | 1 | - | 1 | 1 | 2119740-1 | TAG, IDENTIFICATION | 67 |
| - | 2 | 2 | 2 | 2 | 2168078-1 | SCREW, DRIVE, RH, RoHS | 66 |
| - | 1 | 1 | 1 | 1 | 2119793-1 | LIMITER, ADJUSTMENT BOLT | 63 |
| - | 3 | 3 | 3 | 3 | 992763-5 | SCR, SET, SOC, CONE POINT, M3 X 4.0 | 62 |
| - | - | - | 1 | 1 | 5-18022-5 | SCR, HEX HD CAP, M4 X 6.0 | 59 |
| - | - | - | 1 | 1 | 1338685-1 | PAWL, FEED | 56 |
| - | 1 | 1 | 1 | 1 | 1-5018030-0 | NUT, HEX, REG, RoHS, M3.5 | 52 |
| - | 1 | 1 | 1 | 1 | 1901681-1 | HOLDDOWN, TERMINAL | 51 |
| - | 1 | 1 | 1 | 1 | 1-1752354-7 | STANDOFF, HOLD-DOWN | 50 |
| - | - | - | 1 | 2 | 18023-9 | SCR, SKT HD CAP M4 X 6.0 | 49 |
| - | - | - | - | 1 | 2119652-1 | FEED CAM, PRE FEED | 48 |
| - | 1 | 1 | 1 | 1 | 2079383-7 | SCR, BHSC, RoHS (M8 X 25) | 41 |
| - | 1 | 1 | 1 | 1 | 2119645-1 | DISC, NUMBERED FA WIRE ADJUSTMENT | 40 |
| - | 1 | 1 | 1 | 1 | 2119957-1 | APPLICATOR SHIM PACK | 39 |
| - | 1 | 1 | 1 | 1 | 2119644-1 | RAM WASHER, PRECISION | 38 |
| - | 1 | 1 | 1 | 1 | 1-1752356-8 | SUPPORT, TERMINAL | 34 |
| - | 2 | 2 | 2 | 2 | 2079383-5 | SCR, BHSC, RoHS (M4 X 20) | 33 |
| - | 1 | 1 | 1 | 1 | 2161328-1 | HEX HEAD, FLANGED, M5 X 8mm LONG | 32 |
| - | 1 | 1 | 1 | 1 | 1-1320908-0 | SPACER, STRIP GUIDE | 30 |
| - | 1 | 1 | 1 | 1 | 2119959-2 | ASSEMBLY, STRIP GUIDE | 29 |
| - | 1 | 1 | 1 | 1 | 1-455888-0 | SPACER, CRIMPER | 28 |
| - | 1 | 1 | 1 | 1 | 1320928-2 | STRIP GUIDE | 24 |
| - | 1 | 1 | 1 | 1 | 2168083-2 | SCR, SKT HD CAP, RoHS, M4 X 8.0 | 21 |
| - | 1 | 1 | 1 | 1 | 1-18028-2 | WASHER, FLAT, REG M4 | 20 |
| - | 1 | 1 | 1 | 1 | 2119533-1 | STRIPPER, SIDE FEED | 19 |
| - | 1 | 1 | 1 | 1 | 2119806-1 | INSERT, SHEAR | 13 |
| - | 1 | 1 | 1 | 1 | 3-22280-3 | SPRING, COMPRESSION | 12 |
| - | 1 | 1 | 1 | 1 | 1-356885-4 | STOP, SHEAR | 11 |
| - | 1 | 1 | 1 | 1 | 2119805-1 | SHEAR HOLDER, FRONT | 10 |
| - | 1 | 1 | 1 | 1 | 454276-5 | FLOATING SHEAR, FRONT | 9 |
| - | 1 | 1 | 1 | 1 | 1-1333204-5 | ANVIL, COMBINATION | 8 |
| - | - | - | - | - | - | - | 7 |
| - | - | - | - | - | - | - | 6 |
| - | 1 | 1 | 1 | 1 | 2119757-4 | DEPRESSOR, SHEAR | 5 |
| - | 1 | 1 | 1 | 1 | 238011-4 | BLOCK, CRIMPER SPACER | 4 |
| - | 1 | 1 | 1 | 1 | 4-2119784-0 | CRIMPER, INSULATION O PREMIUM | 3 |
| - | 1 | 1 | 1 | 1 | 1-455888-3 | SPACER, CRIMPER | 2 |
| - | 1 | 1 | 1 | 1 | 1-456405-6 | CRIMPER, WIRE PREMIUM | 1 |
| -77 | -27 | -25 | -22 | -21 | PART NO | DESCRIPTION | ITEM NO |

| DIMENSIONS: | | TOLERANCES UNLESS OTHERWISE SPECIFIED: | | OWN | CHK | APVD | DATE | NAME | PRODUCT SPEC | APPLICATION SPEC | SIZE | CAGE CODE | DRAWING NO | RESTRICTED TO |
|-------------|------------|--|-------------|--|---------------|----------------|--------------|-------|--------------|------------------|------|-----------|------------|---------------|
| mm | 0 PLC ±0.1 | 1 PLC ±0.1 | 2 PLC ±0.02 | 3 PLC ±0.005 | 4 PLC ±0.0005 | ANGLES ±0.0005 | | | | | A1 | 00779 | 2151279 | |
| MATERIAL | FINISH | WEIGHT | SCALE | Customer Accessible Production Drawing | SCALE | 1:1 | SHEET 3 OF 4 | REV B | | | | | | |

| LOC | DIST | REVISIONS | | | | | |
|-----|------|-----------|-----|-------------|------|-----|------|
| | | P | LTN | DESCRIPTION | DATE | DWN | APVD |
| A | 66 | - | - | SEE SHEET 1 | - | - | - |

FEED TYPE MECHANICAL

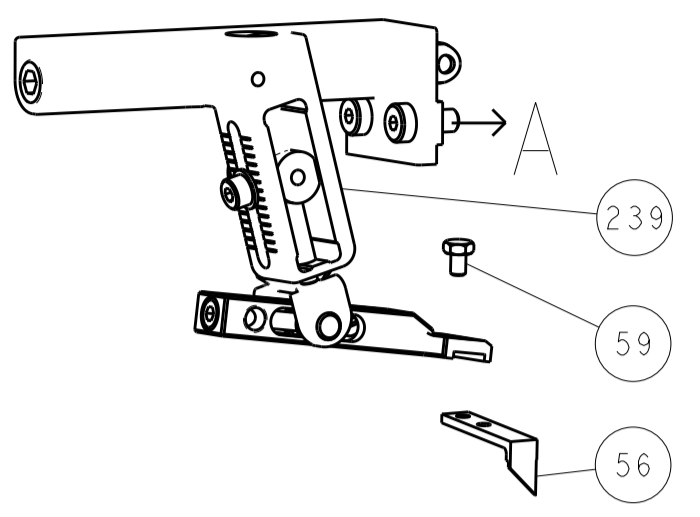

PNEUMATIC

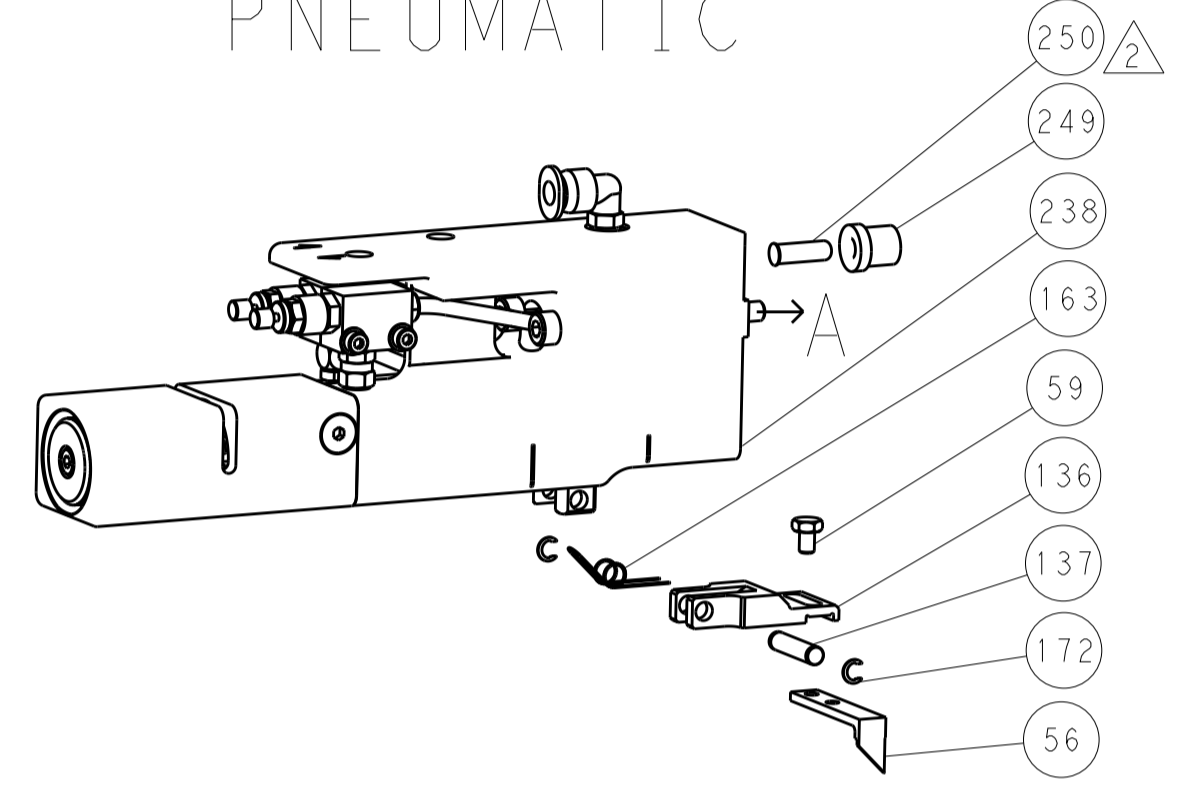

SERVO LATCH PLATE

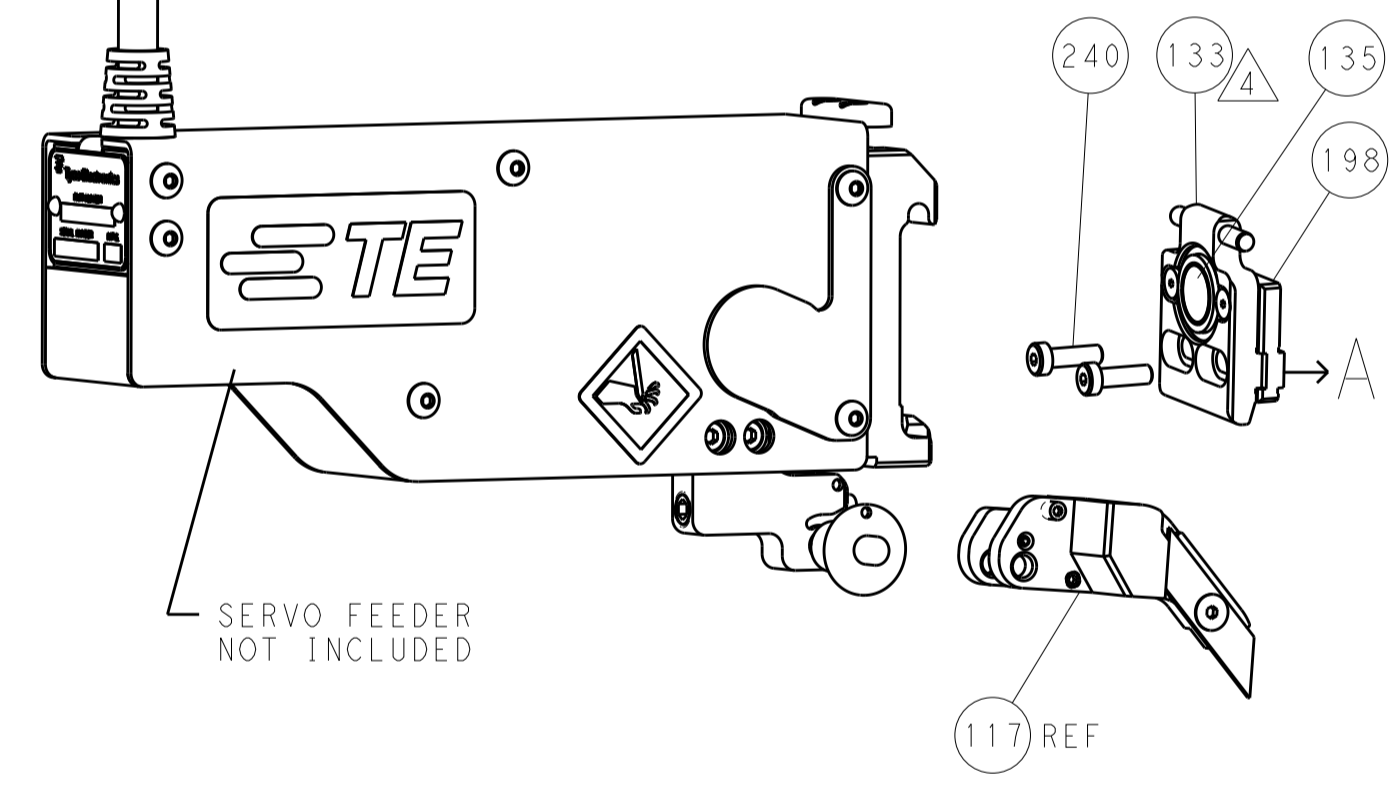

CAM POSITIONS

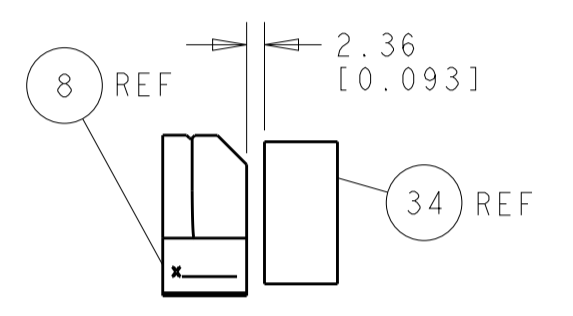
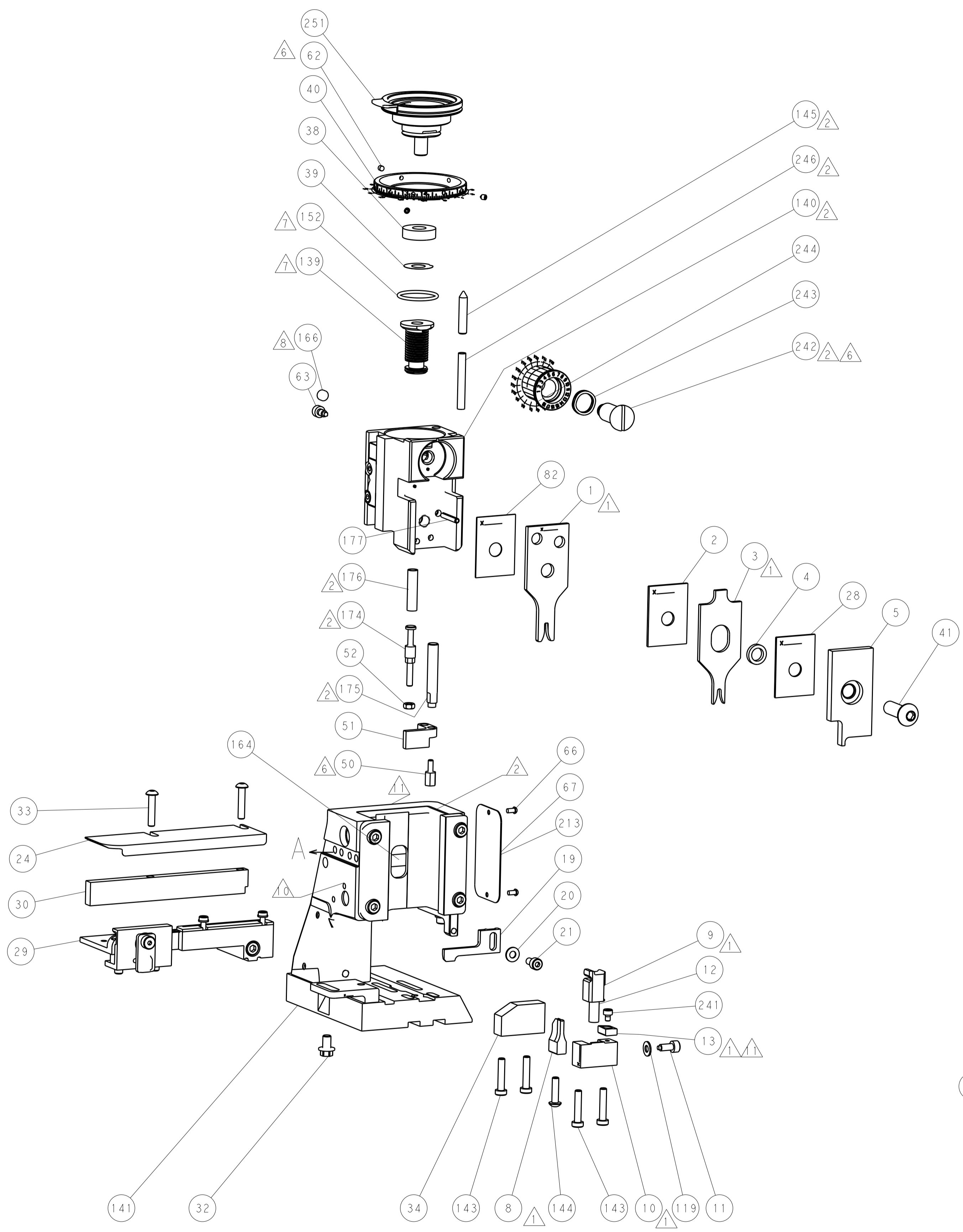
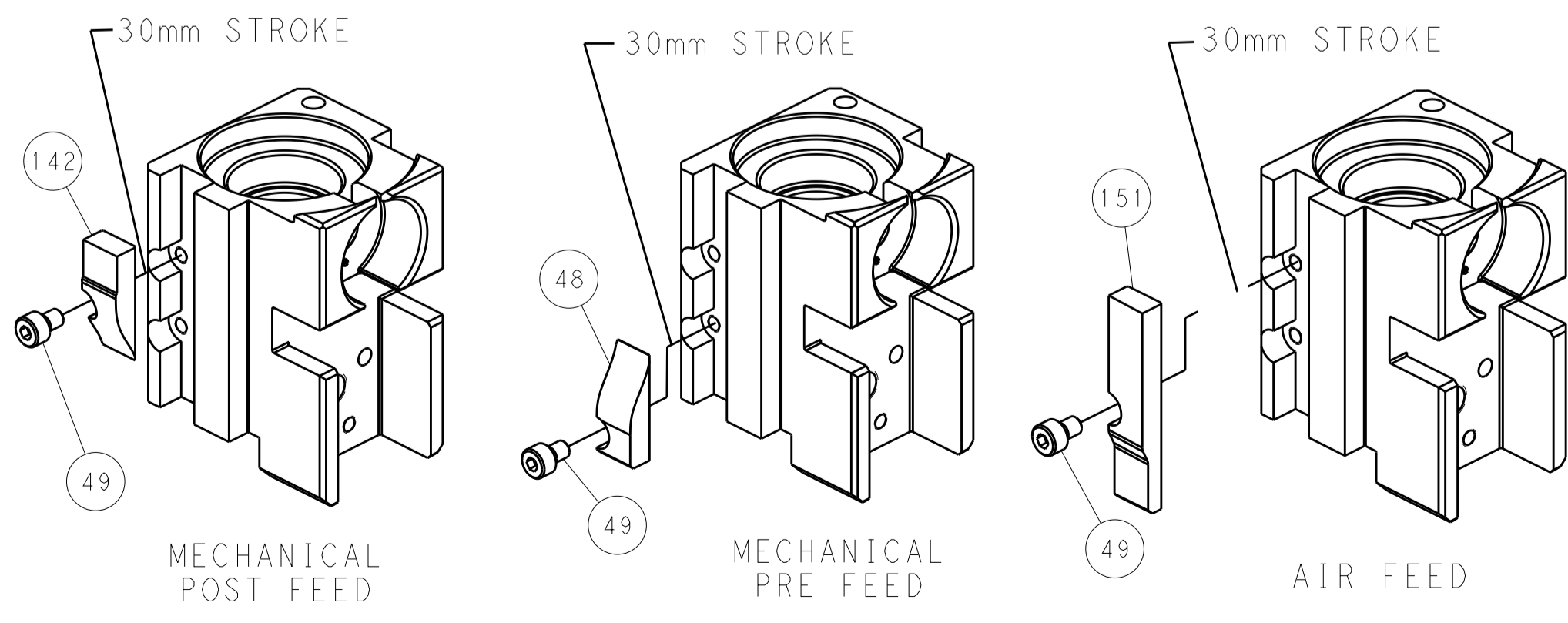

TERMINAL SUPPORT LOCATION

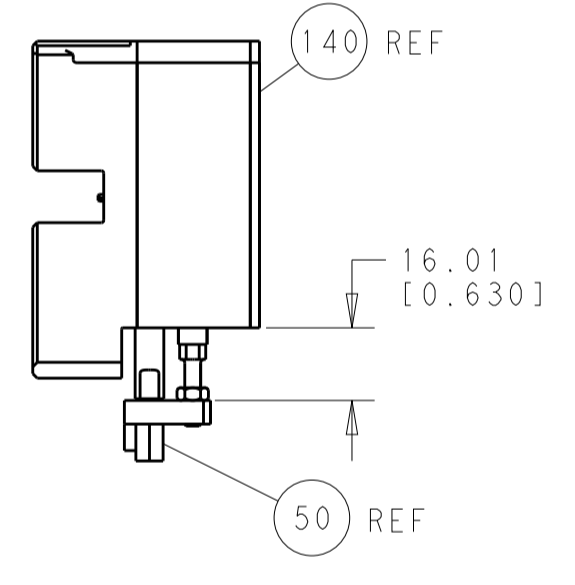

HOLDDOWN SET-UP

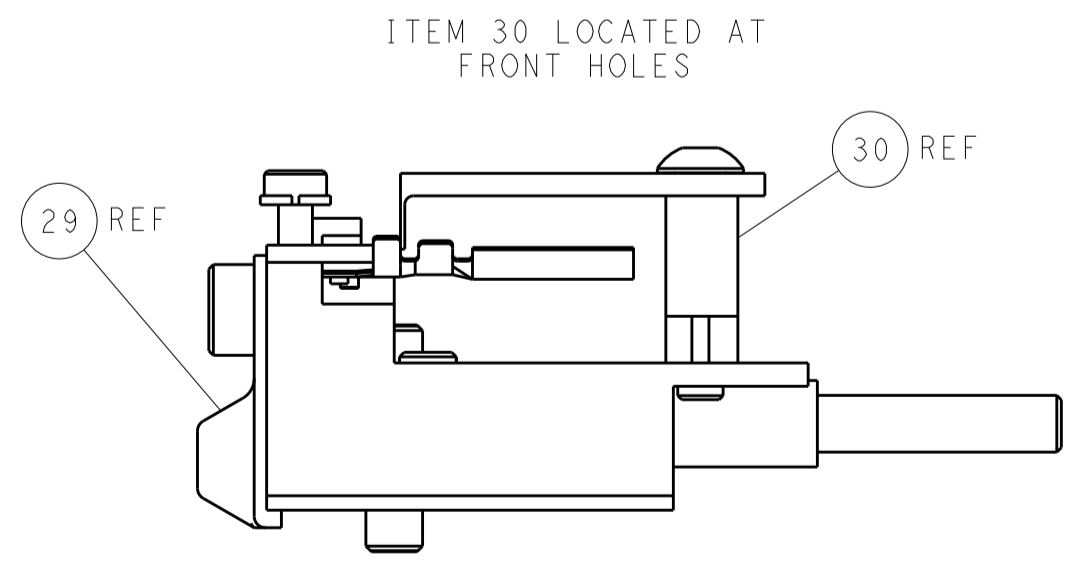

FEED TRACK POSITION GUIDE BY INSULATION BARREL

PACIFIC VERSION
 Shown on sheets 3 of 4 & 4 of 4
 (Atlantic version shown on sheets 1 of 4 & 2 of 4)

| | | | | | | | | | |
|--------------------------|--|---|--|---|--|--|--|---|--|
| DIMENSIONS: mm | | TOLERANCES UNLESS OTHERWISE SPECIFIED: 0 PLC ±.1 1 PLC ±0.1 2 PLC ±0.02 3 PLC ±0.005 4 PLC ±0.0005 ANGLES ±.1 | | DWN R. HUANG 09DEC2011 CHK S. XI 09DEC2011 APVD J. CRUZ 09DEC2011 | | NAME OCEAN SIDE FEED APPLICATOR SIZE CAGE CODE DRAWING NO A1 00779 C-2151279 | | RESTRICTED TO SCALE 1:1 SHEET 4 OF 4 REV B | |
| MATERIAL: . FINISH: . | | | | WEIGHT: . Customer Accessible Production Drawing | | SCALE 1:1 SHEET 4 OF 4 REV B | | SHEETS 1 & 2 ARE NOT REQUIRED FOR PACIFIC VERSION | |