

Aug.1.2018 Copyright 2018 HIROSE ELECTRIC CO., LTD. All Rights Reserved.  
 In case that the application demands a high level of reliability, such as automotive,  
 please contact a company representative for further information.

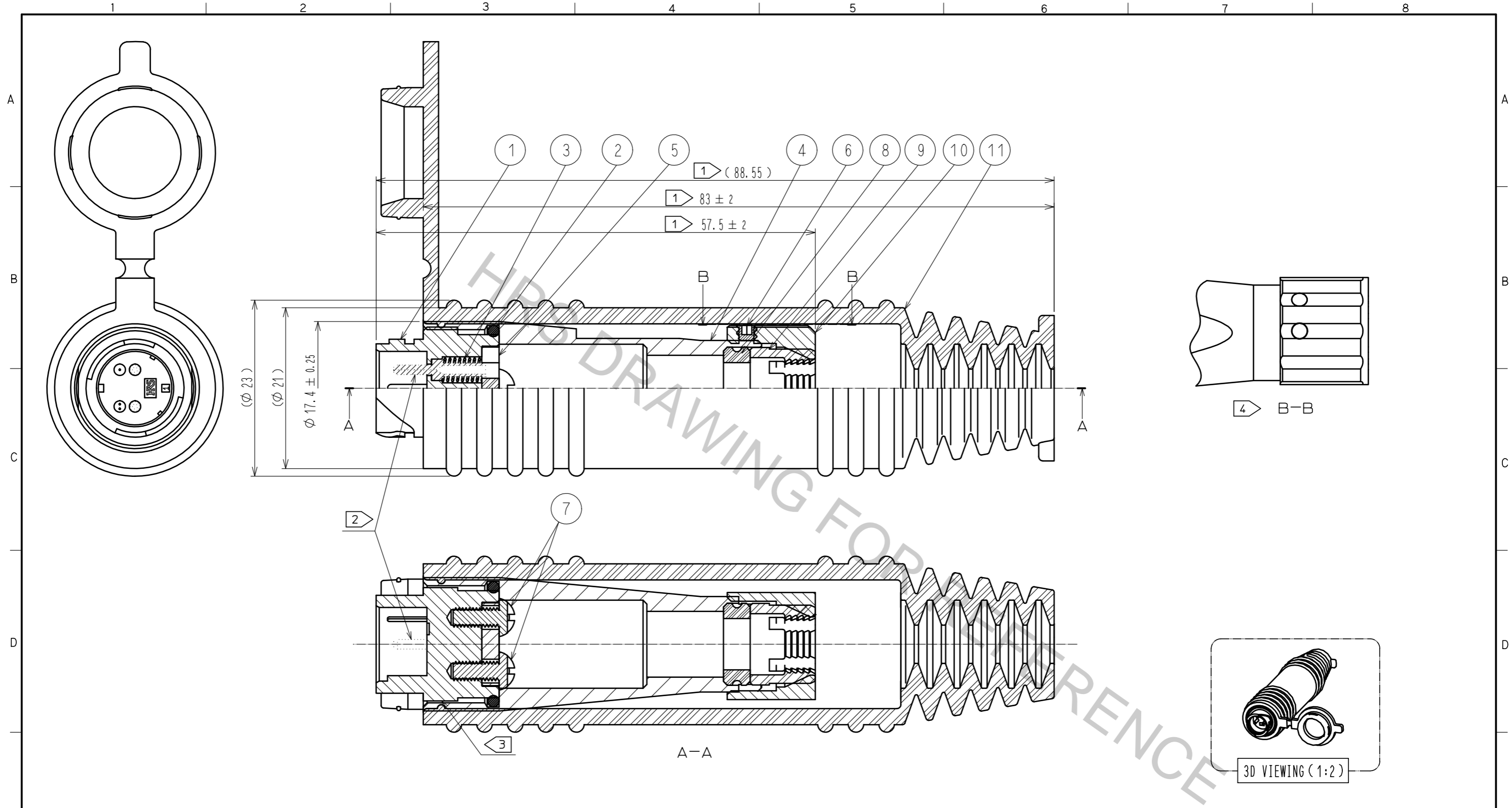

NOTE

- 1 These are indicates the dimensions of after assembling
- 2 Ferrules are not included in this product. MU Ferrules are sold separately.
- 3 Apply adhesive to around the threads of R-shell-J(part No.1) before tighten Hood(part No.4).
- 4 Clamp ring has two holes for fixing hexagon socket screw.  
Tighten the screw at visible either hole with tightening torque 25N·cm. or either hole if both holes are visible.

6	STAINLESS STEEL							
5	PBT RESIN	COLOR:BLACK	11	SILICONE RUBBER	COLOR:BLACK			
4	ALUMINUM ALLOY	ANODIC OXIDE COATING	10	ZINC ALLOY DIE CASTING	NICKEL PLATING			
3	PIANO WIRE	ZINC PLATING * BAKING	9	PA RESIN	COLOR:WHITE			
2	NITRILE BUTADIENE RUBBER	COLOR:BLACK	8	CHLOROPRENE RUBBER	COLOR:BLACK			
1	ZINC ALLOY DIE CASTING	NICKEL PLATING	7	STAINLESS STEEL				
NO.	MATERIAL	FINISH . REMARKS	NO.	MATERIAL	FINISH . REMARKS			
UNITS	mm	SCALE	2 : 1	COUNT	DESCRIPTION OF REVISIONS	DESIGNED	CHECKED	DATE
HIROSE ELECTRIC CO., LTD.		APPROVED	MT. SHIBUTANI	18.02.02	DRAWING NO.	EDC-177028-31-00		
		CHECKED	FS. YOSHIDA	18.02.02	PART NO.	MF10B-WJ6. 5C01-0200(31)		
		DESIGNED	TY. SATO	18.02.02	CODE NO.	CL709-1011-7-31		
		DRAWN	MK. INOUE	18.02.02				