

VI Chip® PRM Evaluation Board

Written by: Ankur Patel
Applications Engineer
February 2013



Contents	Page
<i>Introduction</i>	1
<i>Contents</i>	3
<i>Features</i>	3
<i>Board Description</i>	4
<i>General Components</i>	5
<i>Test Points</i>	7
<i>Sockets</i>	8
<i>Schematic</i>	9
<i>Assembly Drawings</i>	11
<i>Bill of Materials</i>	13
<i>VTM Evaluation Boards</i>	16
<i>Recommended Test Equipment</i>	17
<i>Board Operating Modes</i>	18
<i>Common Features</i>	19
<i>Default/Adaptive Loop Operating Mode: PRM</i>	20
<i>Trim Control</i>	20
<i>AL Control</i>	20
<i>Adaptive Loop Operating Mode: PRM & VTM</i>	21
<i>Remote Sense Operating Mode: PRM</i>	21
<i>Remote Sense Operating Mode: PRM & VTM</i>	23
<i>Trim and Soft Start Adjustment</i>	24
<i>Current Limit Adjustment</i>	25
<i>Slave Operating Mode</i>	26
<i>Paralleling</i>	26
<i>Conclusion</i>	27

Introduction

The PRM® evaluation boards described in this document are designed to use with the PRM family of PRM regulators and demonstrate the benefits of the Factorized Power Architecture™. These evaluation boards are not designed for installation in end user equipment. The system demonstrates the use of a PRM (the pre-regulator module) and a VTM (the current multiplier or the voltage transformation module) for general laboratory evaluation only.

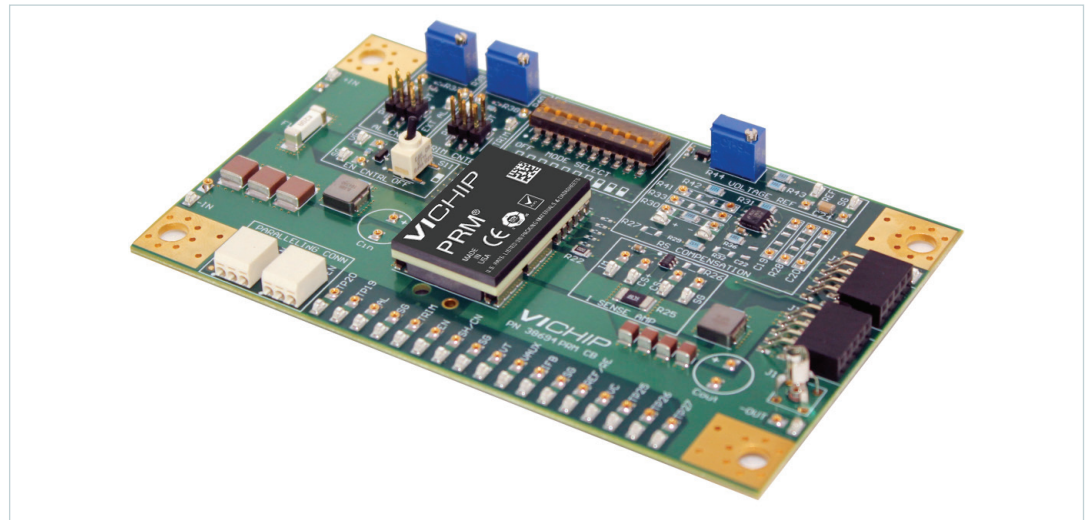

IMPORTANT NOTICE:

Be sure to read this design guide manual thoroughly before using this product. Pay attention to all cautions and warnings.

This user guide is not comprehensive and is not substitute for common sense and good practice. For example:

- When testing electronic product always use approved safety glasses.
- Provide a strain relief for wires and place the system on the bench in such a way as to prevent accidental displacement from bench top.
- Remove the power and use caution when connecting and disconnecting test probes and interface lines to avoid unintentional short circuits and contact with hot surfaces.
- Never use a jumper in place of the fuse. Replace the fuse only with its equivalent type and rating.
- Never attempt to disconnect the evaluation board from a VTM® evaluation board while power is applied. This system is not designed to demonstrate the hot plug capability.

The PRM® evaluation board can be used to demonstrate a stand-alone buck-boost regulator or in conjunction with a VTM evaluation board to enable evaluation of a Factorized Power Architecture™ (FPA) system. There are many combinations possible using PRM and VTM evaluation boards, but the focus in this user guide is using one PRM evaluation board and one VTM evaluation board, with a brief overview of how to parallel boards.

The PRM module evaluation board can be used to configure various modes of regulation depending upon the application requirements. (1) AL Operation: the PRM uses a unique feed-forward scheme that enables precise regulation of an isolated POL voltage without the need for remote sensing and voltage feedback. (2) Remote Sense Operation: the internal regulation circuitry is disabled and an external control loop and current sensor maintain regulation. This affords flexibility in the design of both voltage and current compensation loops to optimize performance in the end application. In Remote Sense Operation, PRM can be set in local sense mode or in non-isolated remote sense mode depending on the application.

Table 1.
Evaluation board numbers
and their ratings

PRM Part Number (PS10)	Evaluation Board Number	Description	Input Voltage (V)	Output Voltage (V)	Output Power (W)
PRM48AF480T400A00	PRD48AF480T400A00	Full-Chip PRM Evaluation Board	48 V (36 V to 75 V)	48 V (20 V to 55 V)	400 W
PRM48BF480T500A00	PRD48BF480T500A00		48 V (38 V to 55 V)	48 V (20 V to 55 V)	500 W
MPRM48NF480M500A00	MPRD48NF480M500A00		48 V (45 V to 55 V)	48 V (20 V to 55 V)	500 W
PRM48JF480T500A00	PRD48JF480T500A00	Half-Chip PRM Evaluation Board	User Configured		
PRM2A01-xxxxxx	PRD2A01-xxxxxx		User Configured		
PRM48BH480T250A00	PRD48BH480T250A00	Half-Chip PRM Evaluation Board	48 V (38 V to 55 V)	48 V (20 V to 55 V)	250 W
MPRM48NH480M250A00	MPRD48NH480M250A00		48 V (36 V to 75 V)	48 V (20 V to 55 V)	200 W
PRM48AH480T200A00	PRD48AH480T200A00		48 V (45 V to 55 V)	48 V (20 V to 55 V)	250 W
PRM48JH480T250A00	PRD48JH480T250A00	Half-Chip PRM Evaluation Board	User Configured		
PRM2A02-xxxxxx	PRD2A02-xxxxxx		User Configured		
PRM2A03-xxxxxx	PRD2A03-xxxxxx	User Configured			
PRM2A04-xxxxxx	PRD2A04-xxxxxx	User Configured			

Refer to the specific PRM data sheet for detail ratings of the device. It is important to remain within the device limits when testing.

These boards make it convenient to evaluate the performance of Vicor's PRM products. All evaluation boards include sockets to allow easy "plug and play" insertion and removal of through-hole components and wires while providing kelvin voltage measurements test points of all pins of the PRM. Evaluation boards are designed to simplify testing of the product by providing test points and sockets for easy connection to standard test-equipment, lugs for input/output connections, connectors to allow easy insertion and removal of the PRM evaluation board and VTM evaluation board.

Please note that Not all evaluation board part numbers have been listed here. Full chip and half chip PRMs of different output power level may be using common full chip and half chip evaluation boards. Design specific components have been arranged in table 5 based on PRM output power level. It is recommended that the user should, first, find out which PRM part number is mounted on evaluation board. Second, please refer to appropriate data sheet for pin functions of PRM and modes of operation. Third, follow the appropriate section of the user guide to use the PRM evaluation board in specific modes of operation.

Contents

All PRM evaluation boards arrive with the following contents.
(The user guide can be downloaded from the www.vicorpower.com)

- 1 x PRM evaluation board
- 1 x VI Chip push pin heat sink
- 2 x VI Chip push pins for heat sink installation
- 2 x VI Chip push pin heat sink grounding clips
- 1 x hardware kit
- 1 x through-hole aluminum-electrolytic input capacitor (C_{IN})
- 1 x through hole resistor for default compensation (R28)
- 1 x through hole capacitor for default compensation (C20)
- 2 x jumpers

Features

1. Input and output lugs for source and load connections
2. Input fuse (appropriately rated)
3. Input filtering and sockets to place through-hole input aluminum-electrolytic capacitor for source decoupling
4. Output filtering and sockets to place through-hole output aluminum-electrolytic capacitor
5. Switch for enabling and disabling the PRM through the ENABLE pin
6. Open drain MOSFET for enabling and disabling the PRM using external source
7. Mode selection switch for various PRM® configurations
8. Trim control selection:
 - a. Using potentiometer
 - b. Using fixed resistor
 - c. Using external voltage source
9. Adaptive Loop control selection:
 - a. Using potentiometer
 - b. Using fixed resistor
 - c. Using external voltage source
10. Output current sensing for output current measurement and current feedback in Remote Sense Operation
11. Sockets and circuits to optimize the external control circuits in Remote Sense Operation.
12. Voltage reference to trim pot for adjusting output voltage set point in Remote Sense Operation.
13. Dual output connectors for transferring the power and signal connections to downstream VTM® evaluation board
14. Oscilloscope probe jack for making accurate output voltage measurements
15. Dual paralleling connectors for ENABLE, SHARE and SGND signal connections to other PRM evaluation board
16. Kelvin voltage test points and sockets for all pins of PRM
17. Test points for current sensing and AC signal injection (RS mode)
18. Provision for installing the heat sink

Board Description

The following section provides a detailed description of the evaluation board components, test points and sockets.

Figure 1.
Board Description

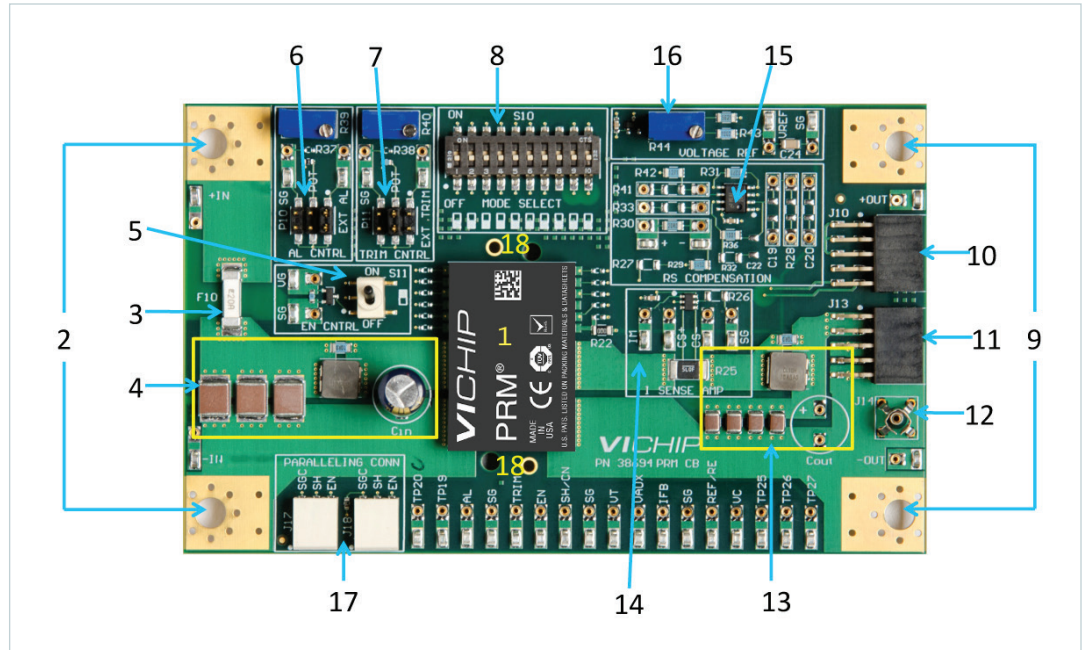
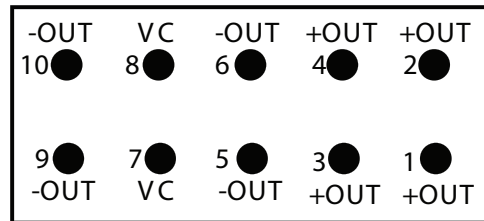
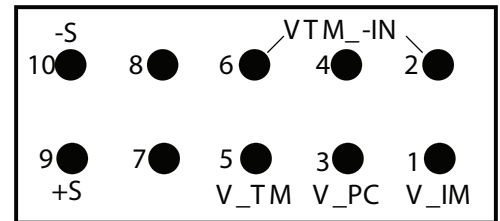

Figure 2.
Power/signal connectors
pinout, front view



J13
Power/signal connector



J10
Signal connector

General Components

1. PRM (PS10)
2. Input lugs: Sized for #10 hardware. Use these for making connection to the input source. This board does not contain reverse polarity protection. Check for proper polarity before applying the power.
3. Input fuse (F10): Appropriately rated.
4. Input filtering: Input capacitor (C_{IN}) and filtering (inductor and ceramic capacitors) allows for stable operation with most input sources. Sockets can be used for easy installation of aluminum-electrolytic input capacitor. It is recommended to place the 22 μ F, 100 V input electrolytic capacitor in the sockets at the input of the PRM®.
5. Enable/Disable switch (S11) and FET switch: When actuator is in top position towards “ON” text on the board, the ENABLE pin will be open and PRM device will be enabled. When actuator is in bottom position towards “OFF” text on the board, the ENABLE pin will be connected to SGND and PRM device will be disabled. When switch S11 is ON, open drain FET can be selected to control the ENABLE pin using external source.
6. Header-jumper for Adaptive Loop control (P10): Provides the option to select and enable Adaptive Loop control:
 - a. Using potentiometer (R39)
 - b. Using fixed resistor
 - c. Using external voltage source
7. Header-jumper for trim control (P11): Provides the option to select and enable the trim control:
 - a. Using potentiometer (R40)
 - b. Using fixed resistor
 - c. Using external voltage source
8. Operating Mode selection switch (S10): For selecting one of the following operating modes:
 - a. Default/Adaptive Loop
 - b. Slave Operation (used in PRM paralleling)
 - c. Remote Sense: Local sensing (single ended)
 - d. Remote Sense: Non-isolated remote sensing (differential)
9. Output lugs: Sized for #10 hardware. Use these lugs to connect the output directly to the load.

General Components (Cont.)

10. Signal connector (J10): Used to transfer VTM[®] PC, IM, TM, -IN and Output Sense signals between the PRM and VTM boards. TM pin of VTM provides feedback to VT pin of PRM to enable temperature compensation in Adaptive Loop Operation of PRM and VTM.
11. Power/Signal connector (J13): Used to transfer power (+OUT/-OUT) and VC to downstream VTM board when used.
12. Output oscilloscope probe Jack (J14): Used for making the accurate scope measurements of the output voltage (i.e. ripple). Remove scope grounding lead and insert probe directly into jack ensuring a good connection between the jack and the probe ground barrel. Do not attempt to install while power is applied. May not be compatible with all scope probes.
13. Output capacitor (C_{OUT}) and output filtering (inductor and ceramic capacitors): Helps to minimize the switching ripple of the output voltage. Sockets can be used for easy installation of aluminum-electrolytic output capacitor.
14. High-side current-sense resistor and current-sense IC (R25 and U10): Current-sense shunt monitors the output current and IC provides the feedback to the IFB pin for constant current limit protection in Remote Sense Operation. Gain is programmed using resistor R26. Constant current limit is set at ~10% above the rated output current of the PRM[®] on all boards.
15. Voltage sense and error amplifier: Dual op-amp provides the voltage sensing and error amplifier function. It can be configured for local voltage sensing at the PRM output or a differential amplifier to allow for non-isolated remote sensing at the VTM[®] output or load in Remote Sense Operation. Sockets are provided for compensation components.
16. Voltage reference and output voltage trim pot (R44) for external voltage control loop: Remote Sense Operation trim pot adjusts the output voltage by increasing and decreasing the error amplifier reference voltage (V_{REF}). Turn clockwise to increase the output voltage and counterclockwise to decrease the output voltage. Sockets can be used for easy installation of soft start ceramic capacitor.
17. Dual paralleling wire to board connectors (J17 and J18): Used for transferring signal pins (ENABLE, SHARE and SGND) in parallel operation from one board to other board. Provides simple strip and insert option. Accepts 18-24AWG solid wires. Spring loaded contact will grab solid wire with no need for soldering. Connection requires for parallel regulator operation are grouped together.
18. Push-pin heat sink and grounding clip mounting holes: Use these holes for installing the optional push pin heat sink and grounding clips included with the board. Use of the heat sink with fan is highly recommended for appropriate cooling of the PRM module.

Test Points Description

Each test point has a socket which accepts 0.015 – 0.025 inch diameter leads for easy installation of solid wires and through-hole components. All the test points are brought out to the edge of the board to allow for easy measurement and/or connection to the user's external circuitry. All test points are labeled and routed to the edge of the board. Each test point is accompanied with an adjacent socket for adding a test lead or to facilitate wiring to external circuitry.

Table 2.
Test points description

Reference Designator	Functional Name	Functional Description
TP30, TP33	+IN, -IN	Input voltage test points provide kelvin connection to input pins of the PRM®. Use these test points for measuring the input voltage of the PRM to avoid error due to interconnect losses.
TP31, TP32	+OUT, -OUT	Output voltage test points provide kelvin connection to output pins of the PRM. Use these test points for measuring the output voltage of the PRM to avoid error due to interconnect losses.
TP34, TP21, TP22	SGND	Signal Ground (SGND) test points are the ground reference for all control circuitry and signal pins of the PRM.
TP28, TP29	CS+, CS-	Used to measure the output current of the PRM across shunt resistor R25.
TP35, TP36	IM, SG	Used to measure the output of current sense IC with reference to SGND.
TP10	SHARE/CONTROL NODE	Used to measure the SHARE/CONTROL NODE signal of the PRM with reference to SGND test point.
TP11	AL	Used to measure the AL signal of the PRM with reference to SGND test point in Adaptive Loop Operation.
TP12	TRIM	Used to measure the TRIM signal of the PRM with reference to SGND test point in Adaptive Loop Operation.
TP13	VAUX	Used to measure the VAUX signal of the PRM with reference to SGND test point.
TP14	REF/REF_EN	Used to measure the REF/REF_EN signal of the PRM with reference to SGND.
TP15	VT	Used to measure the VT signal when connected to VTM® TM pin with reference to SGND in Adaptive Loop Operation.
TP16	ENABLE	Used to measure the ENABLE signal with reference to SGND.
TP17	VC	Used to measure the VC signal with reference to SGND.
TP18	IFB	Used to measure the IFB signal of the PRM with external constant current circuit with reference to SGND in Remote Sense Operation.
TP43, TP44	VREF	Used to measure the voltage reference signal of the error amplifier with reference to SGND in Remote Sense Operation
TP19, TP20	NC, NC	No connect. For internal use only.
TP37, TP38		Can be used to inject the isolated signal of network analyzer for bode plot measurement to measure the stability in Remote Sense Operation.
TP23, TP24	VG, SG	Can be used to connect function generator to control the open drain MOSFET in ENABLE control.
TP39, TP41	EXT AL, SG	Can be used to enable Adaptive Loop control using external source when AL control is selected using header P10 and jumper.
TP40, TP42	EXT TRIM, SG	Can be used to enable TRIM control using external source when TRIM control is selected using header P11 and jumper.

Sockets Description

Each socket accepts 0.015 – 0.025 inch diameter leads for easy installation of solid wires and through-hole components for use with external circuit and test equipment.

Table 3.
Sockets description

Reference Designator	Functional Name	Functional Description
H57, H58	Input Capacitor (C _{IN})	Sockets are used for easy installation of through-hole 100 V rated aluminum-electrolytic capacitor.
H32, H33	Output Capacitor (C _{OUT})	Sockets are used for easy installation of through-hole 100 V rated aluminum-electrolytic capacitor. Ensure proper polarity with short leads while installing.
H49, H53	AL Resistor (R37)	Used for easy installation of fixed through-hole resistor between AL and SGND pins of the PRM when jumper is placed on pin1 and pin2 of the P10 header. Used only with Adaptive Loop and default switch S10 configuration.
H50, H54	Trim Resistor (R38)	Used for easy installation of fixed through-hole resistor between TRIM and SGND of the PRM [®] when jumper is placed on the pin1 and pin2 of the P11 header. Used only with Adaptive Loop and default switch S10 configuration.
H41, H43	Compensation Capacitor (C20)	Used for easy installation of through-hole compensation capacitor C20 in feedback path of error amplifier. Default through-hole 4700 pf capacitor is added in the box. Used only with Remote Sense Operation.
H42, H44	Compensation Resistor (R28)	Used for easy installation of the through-hole compensation resistor R28 in feedback path of the error amplifier. Default through-hole 20 K resistor is added in the box. Used only with Remote Sense Operation.
H39, H40	Integrator Capacitor (C19)	Used for easy installation of through-hole compensation capacitor C19.
H47, H48	Differential Input Resistor (R33)	Used for easy installation of through-hole resistor R33 for non-isolated differential sensing in Remote Sense Operation.
H51, H52	Differential Input Resistor (R41)	Used for easy installation of through-hole resistor R41 for non-isolated differential sensing in Remote Sense Operation.
H55, H56	Soft-start Capacitor (C24)	Used for easy installation of the through-hole capacitor on top of default 0.1uF to soft-start the PRM output voltage in Remote Sense Operation.
H46, H45		Used to insert wires to hook up the network analyzer measuring probes to measure stability in Remote Sense Operation.
H30, H31	CS+ CS-	Used to insert test leads to measure the voltage across R25.

Schematic (Cont.)

Figure 3b.
PRM evaluation
board schematic

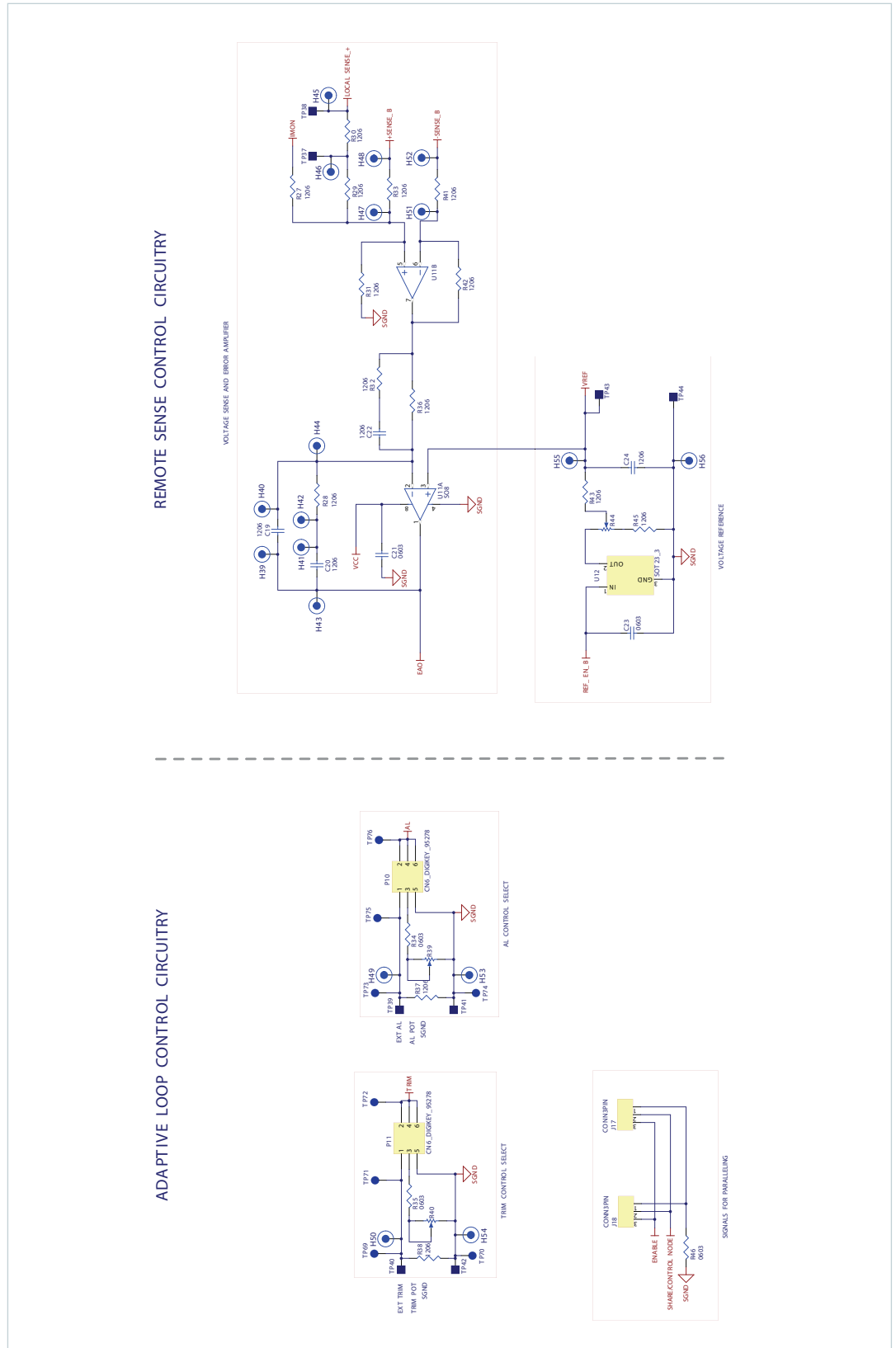

Assembly Drawings

Figure 4a.
Top view: Half-chip
evaluation board
assembly drawing

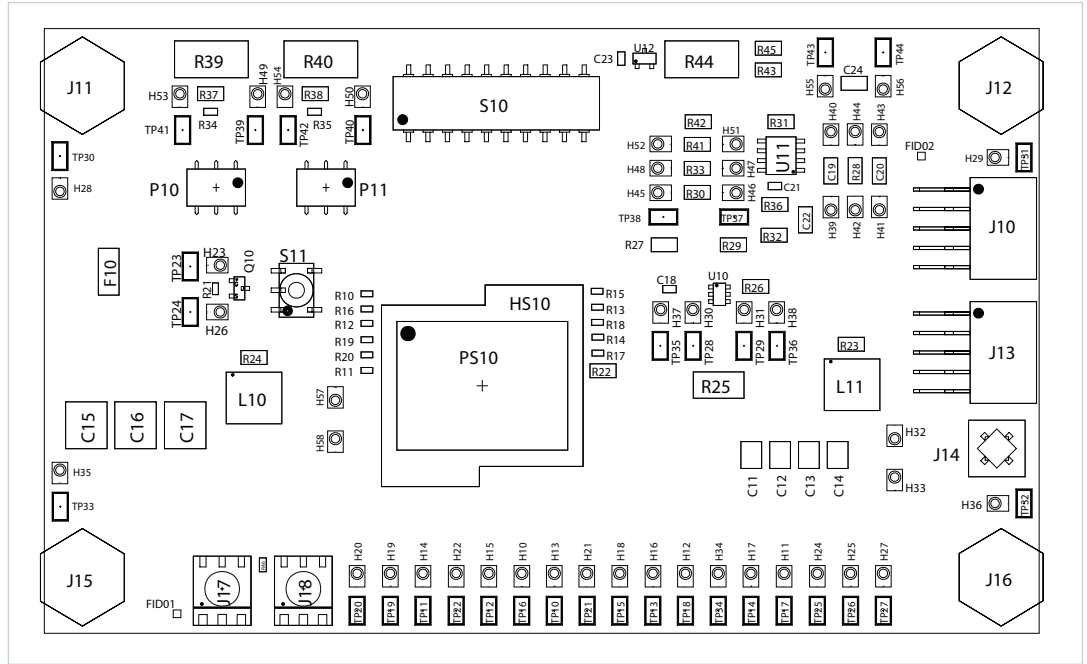
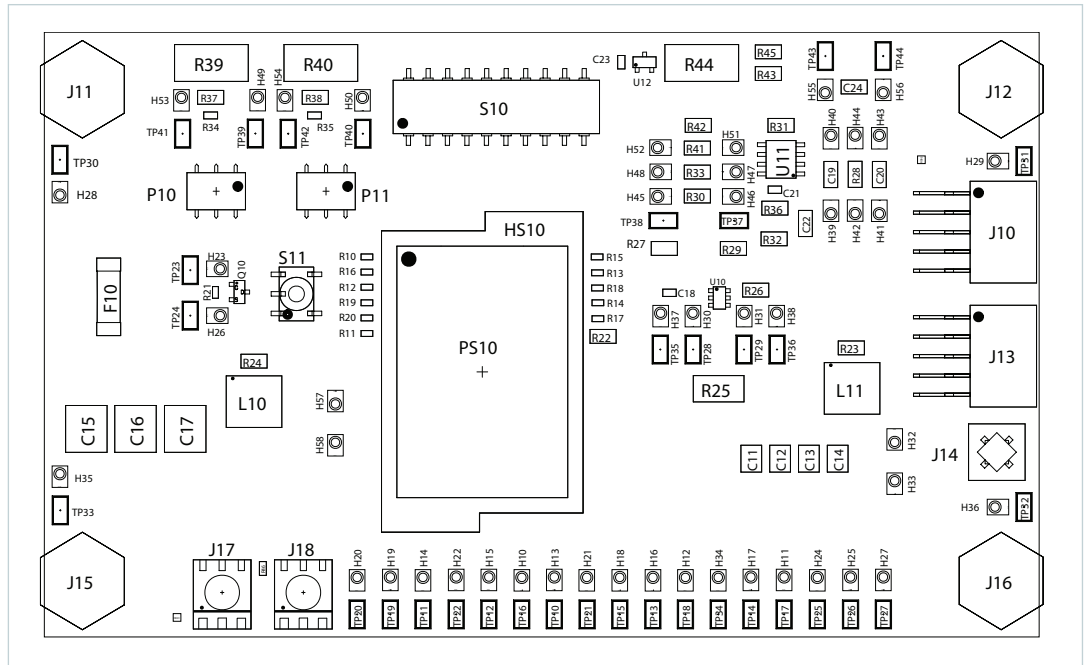

Figure 4b.
Top view: Full-chip
evaluation board
assembly drawing



Assembly Drawings (Cont.)

Figure 4c.
Bottom view: Half-chip/Full-chip
evaluation board
assembly drawing



Bill of Materials

Following table describes the most common components of all four versions of PRM® evaluation boards.

Table 4.
Common components

Reference Designator	Description	Manufacturer	Manufacturer Part Number
C11, C12, C13, C14	CAP X7R 2.2uF 10% 100V 1210 .102 MAX HT	TDK CORP OF AMERICA	C3225X7R2A225KT5LOU
C15, C16, C17	CAP X7R 4.7uF 20% 100V 2220	TDK	C5750X7R2A475M
C18, C21, C23	CAP X7R .01uF 10% 100V 0603	MURATA	GRM188R72A103KA01J
C20* not applied– use sockets	CAP X7R 4700pF 10% 50V RADIAL	AVX CORP	SR155C472KAR
C24	CAP X7R .10uF 10% 100V 1206	AVX CORP	12061C104KATMA
CIN	CAP ALEL 22uF 20% 100V RADIAL 8 X 11.5	PANASONIC	EEU-FC2A220
F10	Design Specific – see Table 5		
H10 to H58	PIN RECPT .015/.025 DIA 0667 SER TH	MILL-MAX MFG CORP	0667-0-57-15-30-27-10-0
J10, J13	CONN 10 PINS 2.54MM PITCH DUAL ROW SM HO	GCT	BG225-10-A-N-A
J14	JACK VERTICAL MECH THRU HOLE	TEKTRONIX	131-5031-00
J17, J18	CONN 3 POS WIRE TO BOARD SMD	AVX CORP	478-6170-2-ND
JUMPER_HEADER	JUMPER SOCKET XJ8A	OMRON ELECTRONICS	XJ8A-0211
L10, L11	IND 0.1uH 20% 32.5A 2525	VISHAY/DALE	IHLP2525CZERR10M01
P10, P11	HEADER 6 PIN STRAIGHT SMT	FCI	95278-101A06LF
PCB	Design Specific – see Table 5		
PS10	Design Specific – see Table 5		
Q10	FET 2N7002 SOT-23	ON SEMICONDUCTOR	2N7002LT1G
R21	RES 10K OHM 1/10W 1% 0603	KOA SPEER	RK73H1J1002FTD
R22	RES ZERO OHM JUMPER 2A 1206	KOA SPEER	RK73Z2BTDD
R23, R24	RES 1 OHM 1/4W 5% 1206	KOA SPEER	RK73B2BTTE1R0J
R25	Design Specific – see Table 5		

Bill of Materials (Cont.)

Following table describes the most common components of all four versions of PRM® evaluation boards.

Table 4 (Cont.).
Common components

Reference Designator	Description	Manufacturer	Manufacturer Part Number
R26	Design Specific – see Table 5 – Remote Sense Operation – set the constant current limit		
R28* – not applied – use sockets	RES 20K OHM 1/4W 1% AXIAL	KOA SPEER	MF1/4DCT52R2002F
R29	RES 54.9K OHM 1/4W 1% SMD 1206	KOA SPEER	RK73H2BTTE5492F
R30	RES 20 OHM 1/4W 1% 1206	KOA SPEER	RK73H2BTDD20R0F
R31, R42	RES 1.27K OHM 1/4W 1 % SMD 1206	KOA SPEER	RK73H2BTTE1271F
R34	RES 0 OHM JUMPER 1A 0603	KOA SPEER	RK73Z1JTDD
R35	RES 4.32K OHM 1/10W 1% 0603	KOA SPEER	RK73H1J4321FTD
R36	RES 1K OHM 1/4W 1% 1206	KOA SPEER	RK73H2BTTE1001F
R39, R40	RES TRIM POT 100K OHM 1/2W 10% TH	MURATA	PV36Y104C01B00
R43	RES 10K OHM 1/4W 1% 1206	KOA SPEER	RK73H2BTTE1002F
R44	RES TRIM POT 10K OHM 1/2W 10% TH	COPAL ELECTRONIC	CT94EY103
R45	RES 5.62K OHM 1/4W 1% SMD 1206	KOA SPEER	RK73H2BTTE5621F
R46	RES 1 OHM 1/10W 1% 0603	PANASONIC	ERJ-3RQF1ROV
S10	MECH SMD 10-POS DIP SWITCH	CTS ELECTROCOMPONENTS	219-10MSTRF
S11	SW TOGGLE SPDT 1 POS SMD	C & K COMPONENTS	GT11MSCBE
TP10 to TP44	TEST POINT, SURFACE MOUNT	KEYSTONE	5017
U10	IC HV I SENSE LMP8645HV TSOT-6	NATIONAL SEMICONDUCTOR	LMP8645HVMKE/NOPB
U11	IC DUAL OPAMP LM6142AIM 8PIN SO	NATIONAL SEMICONDUCTOR	LM6142AIMNOPB
U12	IC VREF 1.25V REF3312 SOT23 3	TI	REF3312AIDBZT

Please note that R28 and C20 are through-hole default compensation components required for Remote Sense operation.

Bill of Materials (Cont.)

Following table describes the design specific components of all four versions of PRM® evaluation boards.

Table 5.
Design specific components

Reference Designator	Description	Manufacturer	Manufacturer Part Number
Evaluation board numbers: PRD48AF480T400A00 and PRD2A02-xxxxxx			
PS10	PRM2A FULL WIDE 400W	VICOR	PRM48AF480T400A00 or PRM2A02-xxxxxx (User Configured)
R26	RES 215K OHM 1/4W 1% 1206	KOA SPEER	RK73H2BTTE2153F
R25	RES I SENSE 5m OHM 1W 1% 2512	VISHAY	WSL25125L000FEA
F10	FUSE 20A 125VAC FAST 10.1X3.1 SMD	LITTELFUSE	0456020.ER
PCB	SNGLTD PCB FULL PRM CONFIG CB	VICOR	39573
Evaluation board numbers: PRD48BF480T500A00, PRD2A01-xxxxxx, PRD48JF480T500A00 and MPRM48NF480M500A00			
PS10	PRM2A FULL NARROW 500W	VICOR	PRM48BF480T500A00 or PRM2A01-xxxxxx (User Configured) or PRM48JF480T500A00 or MPRM48NF480M500A00
R26	RES 174K OHM 1/4W 1% 1206	KOA SPEER	RK73H2BTTE1743F
R25	RES I SENSE 5m OHM 1W 1% 2512	VISHAY	WSL25125L000FEA
F10	FUSE 20A 125VAC FAST 10.1X3.1 SMD	LITTELFUSE	0456020.ER
PCB	SNGLTD PCB FULL PRM CONFIG CB	VICOR	39573
Evaluation board numbers: PRD48AH480T200A00 and PRD2A04-xxxxxx			
PS10	PRM2A HALF WIDE 200W	VICOR	PRM48AH480T200A00 or PRM2A04-xxxxxx (User Configured)
R26	RES 215K OHM 1/4W 1% 1206	KOA SPEER	RK73H2BTTE2153F
R25	RES I SENSE 10m OHM 3W 1% 2512	BOURNS	CRA2512-FZ-R010ELF
F10	LITTLE FUSE 10 AMP R451010.MRL	LITTELFUSE	0451010.MRL
PCB	SNGLTD PCB HALF PRM CONFIG CB	VICOR	38693
Evaluation board numbers: PRD48BH480T250A00, PRD2A03-xxxxxx, PRD48JH480T250A00 and MPRM48NH480M250A00			
PS10	PRM2A HALF NARROW 250W	VICOR	PRM48BH480T250A00 or PRM2A03-xxxxxx (User Configured) or PRM48JH480T250A00 or MPRM48NH480M250A00
R26	RES 174K OHM 1/4W 1% 1206	KOA SPEER	RK73H2BTTE1743F
R25	RES I SENSE 10m OHM 3W 1% 2512	BOURNS	CRA2512-FZ-R010ELF
F10	LITTLE FUSE 10 AMP R451010.MRL	LITTELFUSE	0451010.MRL
PCB	SNGLTD PCB HALF PRM CONFIG CB	VICOR	38693

VTM[®] Evaluation Boards

The PRM[®] evaluation board is designed to work with all types of VTM evaluation boards to facilitate testing of virtually any PRM/VTM combination. The VTM evaluation board contains dual connectors designed to mate with J10 and J13 on PRM evaluation board. The additional signal connector is used to transfer VTM signal pins, as well as S+ and S- signals between boards. The S+ and S- signals are tied to the VTM output using local sense resistors and can be used for implementing non-isolated remote sense as described in a later section. Board also provides the ability to inject an AC signal for measuring the loop response and break the isolation for non-isolated remote sense using PRM and VTM. The TM feedback of the VTM is also transferred through the additional signal connector to make connection with VT pin of the PRM to enable temperature compensation in Adaptive Loop configuration.

Figure 5.
VTM evaluation board

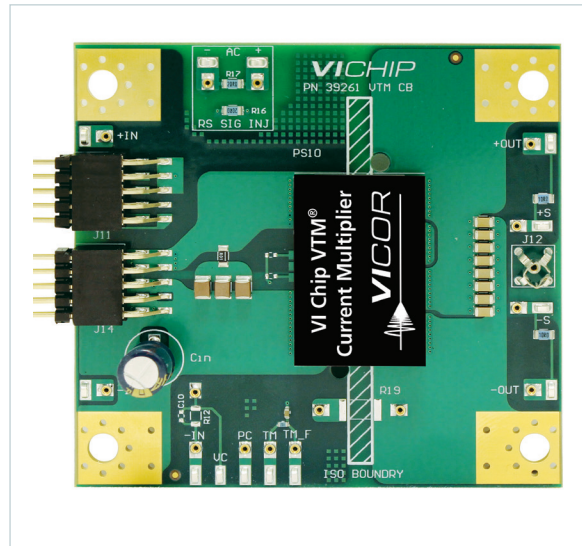

Figure 6.
VTM evaluation board
connector pin out
(front view)

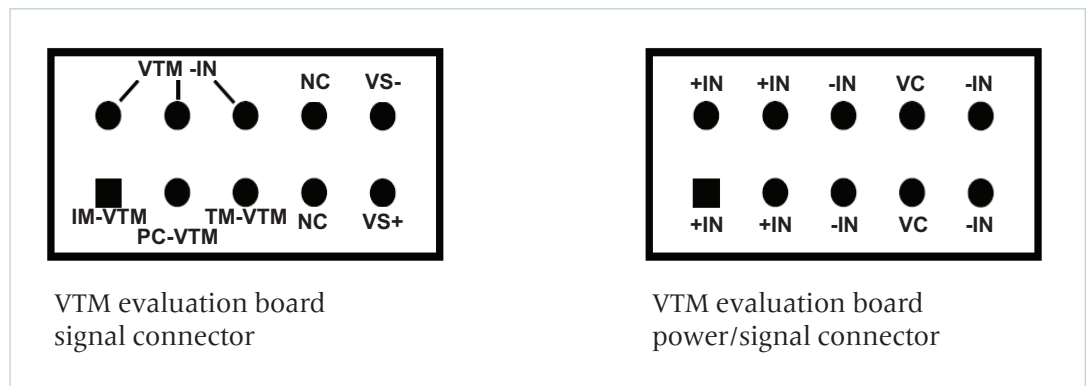
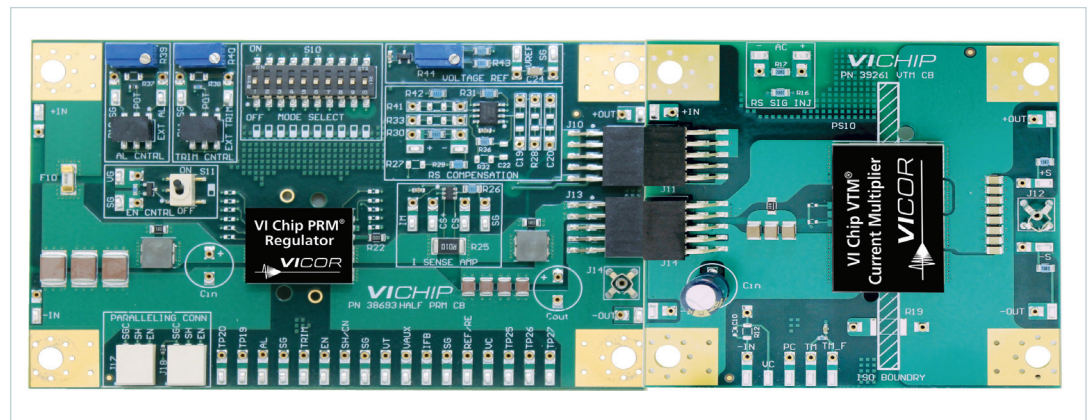

Figure 7.
PRM evaluation board
connection to
VTM evaluation board



Recommended Test Equipment

The following is a list of recommended test equipment.

1. DC power supply: 0 - 80 V, 600 W minimum
2. Load: Rated appropriately based on output voltage, current and power requirements.
3. Digital multi-meters (DMMs)
4. Oscilloscope + probes
5. Function generator (for external enable/disable and trim control)
6. Auxiliary bench voltage supply (for external trim and AL control)
7. Network analyzer (Remote Sense Operation)
8. Interconnect wires, cables and fastening hardware.
9. Calibrated input and output shunts, appropriately rated (for efficiency measurements)
10. Trim pot screwdriver
11. Fan
12. Datasheets of requisite PRM® and VTM® device used.
13. Safety glasses
14. Thin bladed tool for wire extraction from paralleling connectors (AVX part number: 06-9276-7001-01-000)

Push pin heat sink installation

Each PRM® and VTM® evaluation board comes with its own heat sink and push pins for installation. Before testing, it is highly recommended that heat sinks be installed in the appropriate location for each board. When installing the push pin heat sink, use caution not to exceed the maximum compressive on the device listed in the data sheet.

Line and Load connections

- Make sure that input power supply is OFF.
- Connect the input power supply positive lead to the +IN input lug of the evaluation board.
- Connect the input power supply return lead to the –IN input lug of the evaluation board.
- Connect the output lug +OUT to the positive terminal of the electronic load.
- Connect the output lug –OUT to the return terminal of the electronic load.
- Verify proper polarity of the connections.
- Place the input capacitance 22 uF, 100 V.
- Turn the FAN ON.
- Have the latest version of the datasheet.

Board Operating Modes

PRM evaluation board supports both Adaptive Loop and Remotes Sense Operation. Therefore, operating mode selection switch S10 is provided on the board for selection of the following operating modes:

- Default / Adaptive loop using PRM
- Adaptive loop using PRM and VTM
- Remote Sense: local sensing (single ended)
- Remote Sense: non-isolated remote sense (differential)
- Slave (for array operation)

Figure 8.
Mode select switch

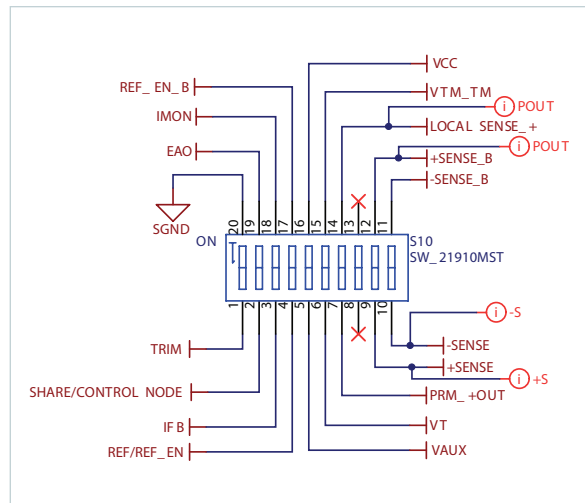

Figure 9.
Switch configuration

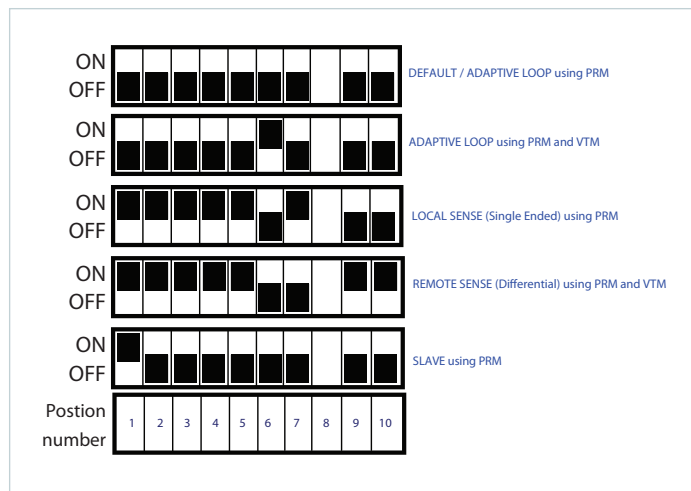
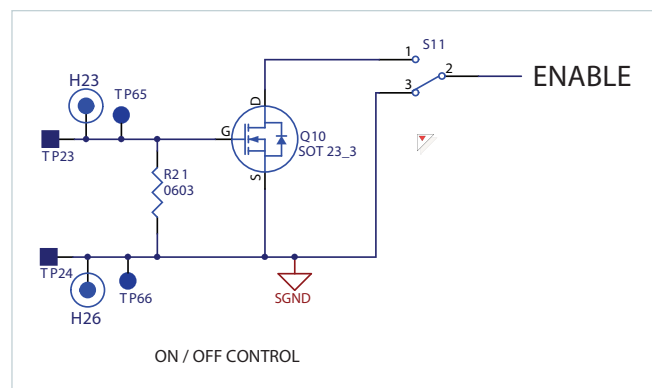

Figure 9 provides the illustration for how to configure the switch for each operating mode.

Common features in all modes of operations

- On / off control to enable and disable the PRM® in the presence of input power.
 - Using switch S11 or
 - Open drain MOSFET using external circuitry or function generator
- Input filtering (inductor and ceramic capacitors)
- Output filtering (inductor and ceramic capacitors)
- Sockets for easy installation of input and output electrolytic capacitor
- Test points for current sensing
- Kelvin test points for measurement of input voltage, output voltage and all signal pins of the PRM.
- Sockets for each test point for easy installation of through-hole components and solid wires to facilitate the wiring to external circuitry and test equipment.

Figure 10.
ON / OFF control



Default / Adaptive Loop operating mode using PRM®

Mode select switch S10 setting: keep the switch OFF at all positions as shown in following illustration. Please note that switch S10 is 10 positions switch.

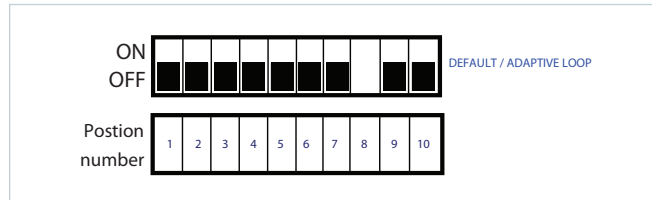

In default operation, PRM maintains its own output voltage using active internal voltage sensing. Also internal current sensing circuit is active for constant current limit. In Adaptive Loop Operation, AL control programs the load line to compensate resistive drops from the PRM output voltage to point of Load. Trim control sets the output voltage other than the default 48 V in the range of 20 V to 55 V.

Default/Adaptive Loop controls

Trim control: Jumper and header select either external trim, trim POT, Trim to SGND option or none. Place jumper across correct position in P11 to enable trim control. Please note that R38 – 1206 resistor footprint is not populated in trim control. Instead, External trim provides option to select sockets for easy installation of fixed resistor or surface mount test points to apply external voltage source.

Trim control provides the option to select the potentiometer R40 using proper jumper setting on header P11 in default / Adaptive Loop Operation. Rotate POT R40 clockwise to increase the TRIM pin voltage and counterclockwise to decrease the TRIM pin voltage. Trim control allows setting the TRIM pin voltage in the range of 1 V to 2.75 V to set the output voltage between 20 V and 55 V.

Figure 11.
Trim control selection

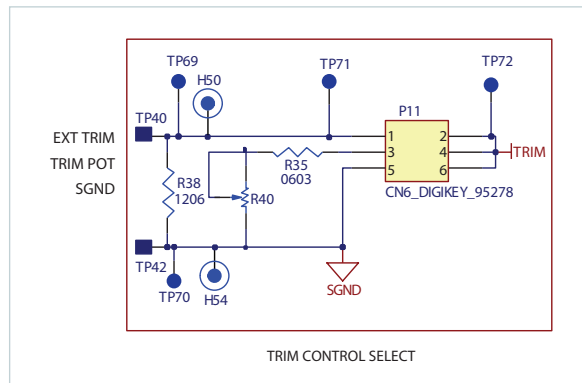

Adaptive Loop control: Jumper and header select either external AL, AL POT, AL to SGND option or none. Place jumper across correct position in P13 to enable AL control. Please note that R37 – 1206 resistor footprint is not populated in AL control. Instead, External AL provides option to select sockets for easy installation of fixed resistor or surface mount test points to apply external voltage source.

AL control provides the option to select potentiometer R39 using proper jumper setting on header P10. Rotate POT R39 clockwise to increase the AL pin voltage and counterclockwise to decrease the AL pin voltage. AL control allows setting the AL pin voltage in the range of 0 V to 3 V to program the PRM load line for Adaptive Loop Operation.

Figure 12.
Adaptive Loop selection

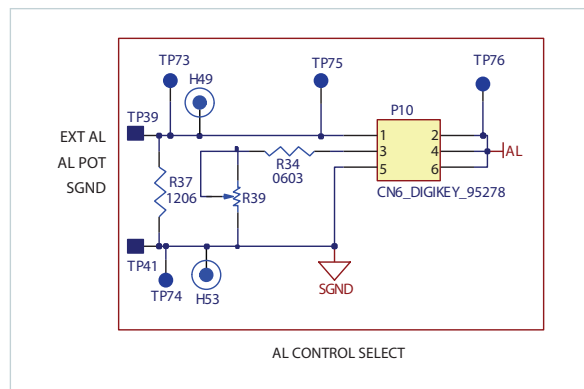

Adaptive Loop operating mode using PRM® and VTM®

Mode select switch S10 setting: keep the switch S10 setting at all positions as shown in following illustration.

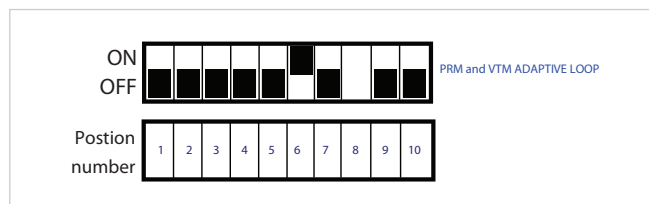

For use when VTM evaluation board is connected to PRM evaluation board. Switch at position 6 is ON, the TM signal of the VTM is transferred through the additional signal connector to make connection with VT pin of the PRM to enable temperature compensation in Adaptive Loop Operation. Other features remain the same in this mode of operation as mentioned in previous mode of operation.

Remote Sense operating mode using PRM®: local sensing (single ended)

Mode select switch S10 setting: keep the switch S10 setting at all positions as shown in following illustration.

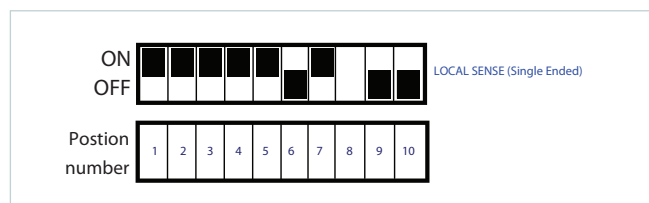

The following table describes the switch configuration.

Table 6.
Switch configuration
in local sensing

Switch Position Number	ON or OFF	Connection
1	ON	TRIM pin is shorted to GND and PRM is configured for Remote Sense Operating mode.
2	ON	CONTROL NODE pin is connected to output of external error amplifier.
3	ON	IFB pin is connected to output of external current sense amplifier to set constant current limit.
4	ON	REF_EN pin is connected to input of the external voltage reference circuit to generate voltage reference for external error amplifier.
5	ON	VAUX pin is connected to power VCC of the op-amp and current sense IC.
6	OFF	TM pin of the VTM is not connected to VT pin of the PRM.
7	ON	PRM +OUT pin is connected to local sense (single ended) of the remote sense control circuitry.
8	Don't care	
9	OFF	See next Remote Sense Operation
10	OFF	See next Remote Sense Operation

Figure 13.

Remote Sense: local sensing
(single ended) control circuitry
BLUE highlight = Pre-installed component
GREEN highlight = user installed component

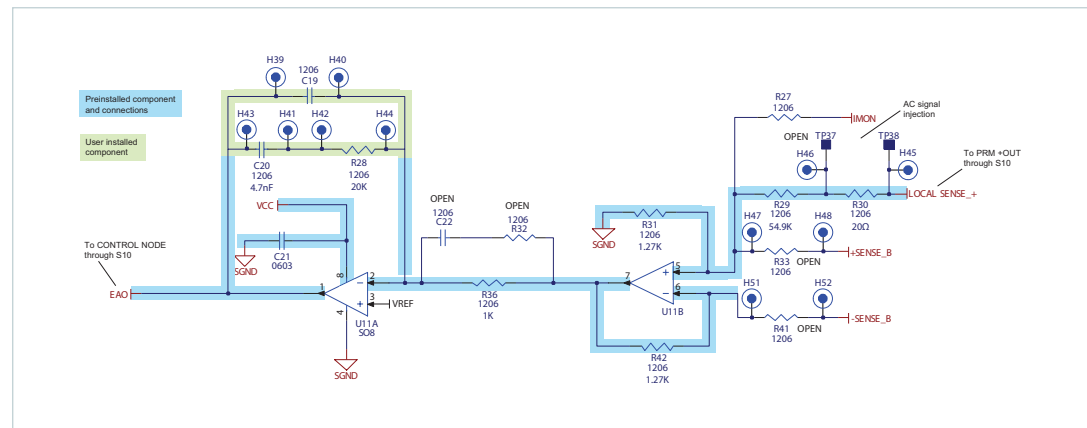

In this configuration, PRM operates in Remote Sense. PRM module output voltage is sensed through divider formed by R29 and R31. U11B is configured as buffer as shown in figure 13 and provides the sense voltage to error amplifier U11A. R33, R41 and R27 are left open, reserved for differential sensing and current sensing. R29 is set to limit the upper trim range based on a maximum reference voltage of 1.25 V. Note that by default compensation components are not installed and required for operation. Default compensation components are provided with the board as described in a later section.

Remote Sense operating mode using PRM® and VTM®: non-isolated remote sensing (differential sensing)

Mode select switch S10 setting: keep the switch S10 setting at all positions as shown in the following illustration.

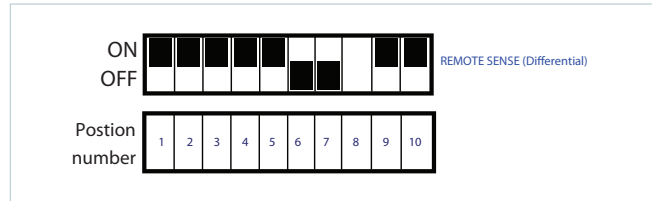

Note: To use this configuration, the VTM isolation must be broken by tying VTM -IN and VTM -OUT together.

The following table describes the switch configuration.

Table 7.
Switch configuration in
differential sensing

Switch Position Number	ON or OFF	Connection
1	ON	TRIM pin is shorted to GND and PRM is configured for Remote Sense Operating mode.
2	ON	CONTROL NODE pin is connected to output of external error amplifier.
3	ON	IFB pin is connected to output of external current sense amplifier to set the constant current limit.
4	ON	REF_EN pin is connected to input of the external voltage reference circuit to generate voltage reference for external error amplifier.
5	ON	VAUX pin is connected to power VCC of the op-amp and current sense IC.
6	OFF	TM pin of the VTM is not connected to VT pin of the PRM.
7	OFF	PRM +OUT pin is NOT connected to local sense (single ended) of the remote sense control circuitry.
8	Don't care	
9	ON	VTM +OUT (+SENSE) pin is connected to positive input (+SENSE_B) of the differential buffer of remote sense control circuitry.
10	ON	VTM -OUT (-SENSE) pin is connected to negative input (-SENSE_B) of the differential buffer of remote sense control circuitry.

Figure 14.

Remote Sense: non-isolated
remote sensing (differential)
control circuitry
BLUE highlight =
Pre-installed component
GREEN highlight =
user installed component

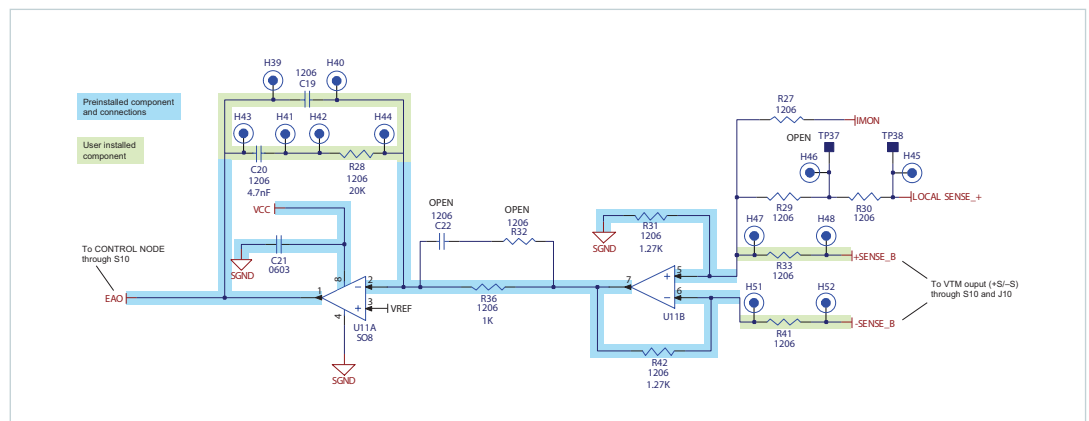

In this configuration, the PRM® and VTM® evaluation boards are connected together to form a PRM / VTM pair and regulation is performed at the VTM module output. The +SENSE and -SENSE connections are made at the VTM output through connector J10. This is a non-isolated configuration and therefore the VTM isolation must be broken by tying the VTM -OUT and VTM -IN pins together. The VTM evaluation board has provisions for easily breaking the isolation. U11B is configured as a differential amplifier with gain set for appropriate output voltage. R33 and R41 set the gain. POT R44 can be used to set the required voltage at the VTM output. Maximum output voltage can be set for maximum 1.25 V reference voltage. R33 and R41 is calculated using following equation.

$$R_{33} = R_{41} = \frac{V_{OUT_SET(MAX)} \cdot 1.27k\Omega}{1.25 V} \quad \text{Equation 1}$$

Where: $V_{OUT_SET(MAX)}$ is the maximum VTM output trim voltage

Please note that R33 and R41 are not populated by default. Sockets can be used to populate through-hole resistors R33 and R41.

In order to configure the evaluation boards for non-isolated remote sense the following steps must be taken:

1. Connect the PRM and VTM evaluation boards together
2. Configure the operating mode switch as described
3. Break the isolation by connecting VTM-IN and -OUT together
4. Calculate and install the appropriate differential sense resistors(R33 and R41)
5. Install compensation components C20 and R28

Remote Sense Compensation components

By default, compensation components are not populated, and are required for operation. Please note that board comes with default through-hole compensation components C20 and R28 that can be used to get a baseline for Remote Sense operation. Sockets can be used for easy installation of C20 and R28. These components are not optimized and will have low bandwidth response. Transient response can be improved by adjusting the compensation components as outlined in the PRM datasheet.

It is recommended to use a network analyzer to measure the closed loop frequency response when adjusting compensation. The PRM and VTM boards provide test points which can be used to inject the network analyzer AC signal and measure the closed loop response.

For PRM Remote Sense mode (single ended local sense), test points TP37/TP38 and H46/H45 are in series between the PRM +OUT and the voltage sense resistors and should be used.

For PRM-VTM Remote Sense mode (differential sense) test points are provided on the VTM board in series with the +S connections (Labeled "AC Sig Inj +/-") and should be used.

Trim and soft-start adjustment in Remote Sense Operation

Trim and soft start adjustment in Remote Sense Operation is set by the reference voltage network shown below. The PRM evaluation board is normally configured for a 20 V to 55 V trim range. Trim POT R44 is used to trim the output voltage in Remote Sense Operation.

The slew rate of the output voltage during startup may be controlled by controlling the rate-of-rise of the voltage at VREF node. This can be achieved using soft-start capacitance C24. By default, C24 is populated with 0.1uF ceramic capacitance. Sockets H55 and H56 can be used for installation of additional through-hole soft-start capacitance. It is not recommended to extend the soft start beyond 10msec.

Figure 15.
Voltage Reference circuit

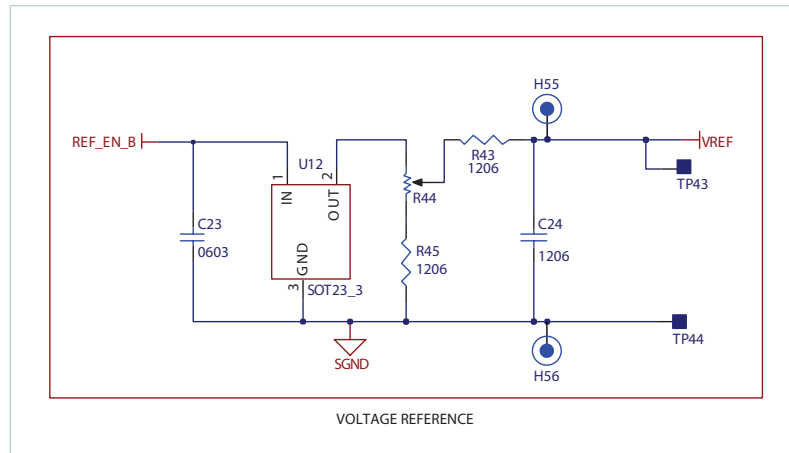

Current limit adjustment in Remote Sense Operation

In Remote Sense Operation, current feedback is provided externally. The current limit set point is a function of the current sense amplifier gain, the shunt resistor and the internal current limit threshold of PRM. Full chip PRM evaluation board has 5 mΩ current shunt whereas half chip PRM evaluation board has 10mΩ current shunt. The IFB current limit threshold is fixed at 2.0V. The gain of the current sense amplifier can be changed per Equation 2 in order to adjust the current limit. Resistor R26 set the gain of the current sense amplifier. R25 is the current shunt.

$$G_{CS} = \frac{V_{IFB_IL}}{I_{LIMIT(SET)} \cdot R_{25}} \quad \text{Equation 2}$$

By default, R26 is installed for the current limit approximately 10% above rated output current.

The current limit setpoint can be changed by adjusting the value of R26 and appropriately setting the gain of the current sense IC.

Slave operating mode (Arrays)

Mode select switch S10 setting: keep the switch S10 setting at all positions as shown in following illustration.

Slave configuration for Adaptive Loop Master. Master/Slave configured PRM parallel arrays

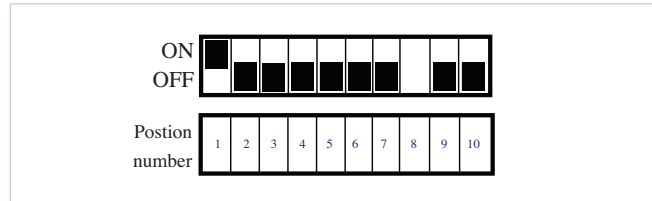

Slave configuration for Remote Sense Operation. Slave configured PRM parallel arrays

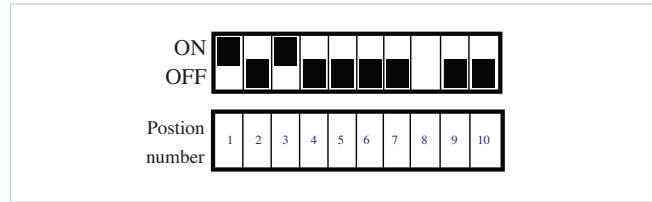

Slave operation is required for constructing arrays of parallel devices as described in the next section. Switch at position 1 is ON and switch at rest of the positions are OFF. When switch at position 1 is ON, TRIM pin of the PRM is shorted to SGND and PRM is configured as a slave. When a PRM is configured as slave, the internal voltage and current sensing circuitry are disabled and slave PRMs receive their control signal (SHARE) from a master PRM or external remote sense circuit.

For Remote Sense operation parallel array where all PRMs are configured as slave, switch at position 3 should be ON to enable the constant output current limit.

Paralleling

The paralleling and current sharing capability of the devices can be demonstrated by stacking multiple evaluation board and interconnecting the inputs and outputs with standoffs of sufficient current rating to create a parallel array. See Figure 16 below. One board should be configured normally for Adaptive Loop or Remote Sense operation and placed on top for easy access to control circuitry. The remaining PRMs should be configured as Slaves and placed underneath.

When paralleling PRMs, the ENABLE, SHARE and SGND pins should be connected together. Dual paralleling wire to board connectors (J17 and J18) are used for transferring signal pins (ENABLE, SHARE and SGND) in parallel operation from board to board. These connectors provide simple strip and insert option and accept 18-24AWG solid wires. SHARE and SGND wires can be twisted to minimize noise pick-up. Note that when using J17 and J18, SGND pins will be connected together through an on board 1 OHM series resistors to decouple signal grounds.

VTM boards can also be connected in parallel to create high power PRM-VTM arrays. VTM input and outputs need to be connected in parallel using same size standoffs. Each VTM requires a VC signal from a PRM in order to start and it is recommended to connect one PRM VC to one VTM VC using the connector J13 when possible. If needed a single PRM VC can be used to drive up to two VTMs (will require additional off board connections).

Figure 16.
Paralleling of PRM
evaluation board

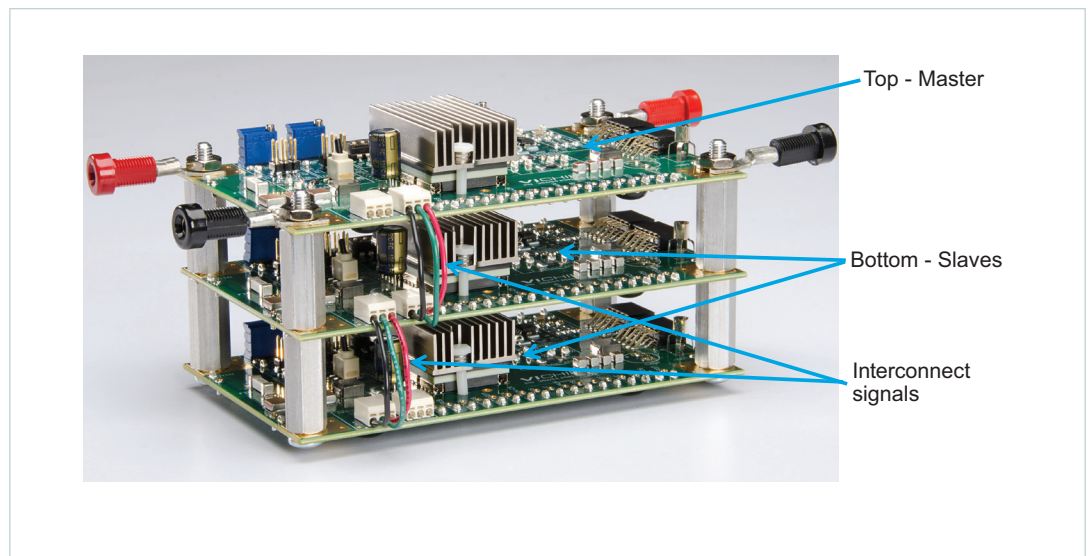

Conclusion

The PRM® evaluation board is a flexible tool which allows users to implement and perform basic testing on various configurations, including PRM-VTM® module combinations. This user guide covers some basic topics; however, it cannot describe every scenario. If additional information required, please contact Vicor Applications Engineering.

The Power Behind Performance